

Robert J. Pease

TOWN COUNCIL AGENDA
TOWN COUNCIL CHAMBERS
740 MAIN STREET
EAST HARTFORD, CONNECTICUT
JULY 15, 2014

2014 JUL 10 A 11: 31
TOWN CLERK
EAST HARTFORD

6:30 P.M. Executive Session
7:00 P.M. Public Hearing

=====

Announcement of Exit Locations (C.G.S. § 29-381)

Pledge of Allegiance

7:30 p.m.

1. CALL TO ORDER
2. AMENDMENTS TO AGENDA
3. RECOGNITIONS AND AWARDS
 - A. Beautification Awards – June 2014:
 - Residential Category:
 1. 179 Harvest Lane: The Johns Family
 2. 180 Harvest Lane: The Keena Family
 - Community Pride Award: Goodwin College 403 Main Street:
4. OPPORTUNITY FOR RESIDENTS TO ADDRESS THE COUNCIL ON AGENDA ITEMS
 - A. Other Elected Officials
 - B. Other Residents
 - C. Mayor
5. APPROVAL OF MINUTES
 - A. June 17, 2014 Executive Session
 - B. June 17, 2014 Regular Meeting
6. COMMUNICATIONS AND PETITIONS
 - A. General Obligation Bonds – TD Bank
7. OLD BUSINESS
8. NEW BUSINESS
 - A. The Town of East Hartford and Local 1174, Council 4, AFSCME, AFL-CIO
 1. Approval of the Collective Bargaining Agreement
 2. Contingency Transfer
 - B. Energy Performance Contract III – Ameresco, Inc.:
 1. Presentation
 2. Energy Performance Resolution
 3. Municipal Tax-exempt Lease Purchase Financing Resolution
 - C. Reallocation of LoCIP Funds re: EHHS Tennis Courts
 - D. Approval of Sale of Tax Liens
 - E. Refund of Taxes
 - F. Setting a Public Hearing Date of August 5, 2014 @ 7PM in Town Council Chambers re: Appropriation of \$15,000,000 for The Planning, Design, Construction & Reconstruction of Town Roads and Parking Lots

- G. Appointments to the Patriotic Commission:
 - 1. Robert Falkevitz; term to expire December 2015
 - 2. Timothy Siggia; term to expire December 2016
- H. Referral to Real Estate Acquisition & Disposition Committee re: 1855 and 1859 Main St.
- I. Referral to Ordinance Committee re: PA No. 14-124
- J. Outdoor Amusement Permit Application: Gengras Harley-Davidson Fall Open House

- 9. OPPORTUNITY FOR COUNCILLORS TO DIRECT QUESTIONS TO THE ADMINISTRATION

- 10. COUNCIL ACTION ON EXECUTIVE SESSION MATTERS
 - A. Brookside Commons v Town of East Hartford
 - B. TE Realty Enterprises v Town of East Hartford

- 11. OPPORTUNITY FOR RESIDENTS TO SPEAK
 - A. Other Elected Officials
 - B. Other Residents
 - C. Mayor

- 12. ADJOURNMENT (next meeting: August 5th)

Robert J. Beck

OFFICE OF THE
TOWN COUNCIL

TOWN OF EAST HARTFORD

740 Main Street

East Hartford, Connecticut 06108

2014 JUL 11 A 9:40

TOWN CLERK (860) 291-7208
EAST HARTFORD (860) 291-7389

DATE: July 11, 2014

TO: Town Council

FROM: Rich Kehoe
Town Council Chair

RE: Tuesday, July 15, 2014 7:00 P.M. Town Council Chambers

In accordance with Section 3.3 (a) of the Town Charter and pursuant to Connecticut General Statutes §7-163e, a Special Meeting of the Town Council will be held as follows:

Tuesday, July 15, 2014

7:00 p.m.

Town Council Chambers

The purpose of the meeting is to hear public comment on the proposed sale of 26 Bissell Street to TAB Computer Systems, Inc.

cc: Town Clerk
Mayor Leclerc
Rich Gentile, Assistant Corporation Counsel
Eileen Buckheit, Director of Development

Robert J. Ross

OFFICE OF THE
TOWN COUNCIL

TOWN OF EAST HARTFORD

740 Main Street
East Hartford, Connecticut 06108

JUN 19 A 11:30 291-7208

TOWN CLERK FAX (860) 291-7389
EAST HARTFORD

June 19, 2014

Please publish the following legal notice in **Zone 4** of the Hartford Courant on **Wednesday, July 2nd and Wednesday, July 9th**. Mail bill to the East Hartford Town Council Office, 740 Main Street, East Hartford, CT 06108.

LEGAL NOTICE

Public notice is hereby given that the Town Council of the Town of East Hartford, Connecticut, will hold a public hearing on **Tuesday, July 15, 2014 at 7:00 p.m.** in the Town Council Chambers, 740 Main Street, East Hartford, Connecticut, to hear public comment on the proposed sale of 26 Bissell Street to TAB Computer Systems, Inc.

Any person(s) wishing to express an opinion on this matter may do so at this meeting.

Angela Attenello
Town Council Clerk

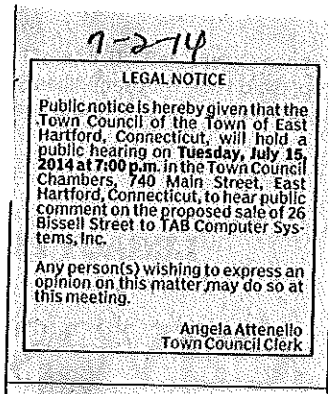

Robert J. Paek

2014 JUN 23 A 10: 08

TOWN COUNCIL MAJORITY OFFICE

JUNE 17, 2014

TOWN CLERK
EAST HARTFORD

EXECUTIVE SESSION

PRESENT Chair Richard F. Kehoe, Majority Leader Barbara-Ann Rossi, Minority Leader
Esther B. Clarke, Councillors Marc I. Weinberg, Linda A. Russo, Ram
Aberasturia, Patricia Harmon and Anita D. Morrison

ABSENT Vice Chair William P. Horan, Jr.

ALSO
PRESENT Scott Chadwick, Corporation Counsel

CALL TO ORDER

Chair Kehoe called the meeting to order at 7:10 p.m.

MOTION By Anita Morrison
seconded by Ram Aberasturia
to go into Executive Session to discuss the case of Debbie Ahern vs
Town of East Hartford.
Motion carried 8/0.

MOTION By Anita Morrison
seconded by Ram Aberasturia
to go back to Regular Session.
Motion carried 8/0.

ADJOURNMENT

MOTION By Anita Morrison
seconded by Ram Aberasturia
to adjourn (7:23 p.m.)
Motion carried 8/0.

Attest

Richard F. Kehoe
Richard F. Kehoe
Town Council Chair

Robert J. Beck

EAST HARTFORD TOWN COUNCIL

2014 JUN 23 A 10:08

TOWN COUNCIL CHAMBERS

TOWN CLERK
EAST HARTFORD

JUNE 17, 2014

PRESENT Chair Richard F. Kehoe, Majority Leader Barbara-Ann Rossi, Minority Leader Esther B. Clarke, Councillors Marc I. Weinberg, Linda A. Russo, Ram Aberasturia, Patricia Harmon and Anita D. Morrison

ABSENT Vice Chair William P. Horan, Jr.

CALL TO ORDER

Chair Kehoe called the meeting to order at 7:32 p.m. The Chair announced the exit locations in accordance with Connecticut General Statutes §29-381, after which the Council joined him in the pledge of allegiance.

The Chair called for a moment of silence to honor the life of Carl Edwin "Ed" Carlson, a longtime resident of East Hartford who served the community in many ways, including as a Justice of the Peace, a member of the Commission on Aging and served in the East Hartford Interfaith Ministry. He will be missed.

OPPORTUNITY FOR RESIDENTS TO ADDRESS THE COUNCIL ON AGENDA ITEMS

Susan Kniep, 44-46 and 50 Olde Roberts Street, spoke on the following agenda items: (1) the year-end results; (2) CT Brownfields grant; (3) proposed \$15M road improvement bond referendum; (4) Youth Services Prevention Grant; and (5) the lease for the East Hartford Community Cultural Center.

Mayor Leclerc spoke to the following issues: (1) CT Brownfields grant will be used to clean and abate the Daley Court property; (2) the ribbon-cutting for 48 Branch Drive will take place Friday, June 20th; (3) the town will participate in the Governor's Emergency Preparedness Plan on Monday, June 23rd; (4) congratulated all the 2014 East Hartford graduates; (5) East Hartford Officer Steven Grossi and K-9 Hades took 2nd place at the Daniel Wasson Awards for their continued heroic efforts; (6) the mosquito control program is progressing; and (7) the town's Health Department is working with the East Hartford Housing Authority on a bed bug prevention and remediation seminar.

APPROVAL OF MINUTES

June 3, 2014 Public Hearing/Ordinance Revisions

MOTION By Barbara Rossi
seconded by Pat Harmon
to approve the minutes of the June 3, 2014 Public Hearing.
Motion carried 8/0.

June 3, 2014 Regular Meeting

MOTION By Barbara Rossi
seconded by Ram Aberasturia
to **approve** the minutes of the June 3, 2014 Regular Meeting.
Motion carried 8/0.

COMMUNICATIONS AND PETITIONS

Resignation of Charles Clarke from the Patriotic Commission

Chair Kehoe announced that Charles "Chuck" Clarke has resigned from the Patriotic Commission and thanked him for his service to the community.

NEW BUSINESS

End of Fiscal Year 2013-2014:

Preliminary Year-end Financial Results

Michael Walsh, Finance Director, reviewed the 2013-2014FY results with the Town Council. Because of a harsh winter, it was a difficult fiscal year due to public works and public safety overtime and road clearing costs. However, tax collections are strong and building fees have increased. Fund Balance is projected to be 8.4% of the total budget, which is above the benchmark that rating agencies use to assess a town's financial stability.

Interdepartmental Budget Transfers

MOTION By Barbara Rossi
seconded by Esther Clarke
to **approve** the interdepartmental transfers for fiscal year 2013-2014 consistent with the transfers listed in a memorandum from Finance Director Michael Walsh to Mayor Marcia Leclerc dated June 17, 2014 totaling \$803,000 in transfers within the General Fund as follows:

| General Fund To Account Number | Name | Amount |
|-----------------------------------|--------------------------------------|---------|
| G2300-60110 | Human Resources - Permanent Services | 32,000 |
| G2600-60110 | Youth Services - Permanent Services | 3,000 |
| G5203-60141 | Police Operations - Overtime | 135,000 |
| G5317-60141 | Fire Suppression - Overtime | 525,000 |
| G7300-60141 | Public Works - Highway - Overtime | 58,000 |

| | | |
|--------------------------|--------------------------------------|----------------|
| G9430-60110 | Senior Services - Permanent Services | 5,000 |
| G9700-63244 | Capital Improvement - EPC Lease | 15,000 |
| G9842-63129 | Planning and Zoning - Consultant | 30,000 |
| | TOTAL | <u>803,000</u> |
| General Fund From | Name | Amount |
| Account Number | | |
| G1100-63134 | Town Council - Internal Audit | 11,000 |
| G2100-60110 | Mayor's Office - Permanent Services | 25,000 |
| G2400-60110 | Library - Permanent Services | 175,000 |
| G3300-62349 | Information Technology - Software | 75,000 |
| G4100-60110 | Development - Permanent Services | 15,000 |
| G6100-60110 | Inspections - Permanent Services | 34,000 |
| G8100-60110 | Park and Rec. - Permanent Services | 60,000 |
| G9200-60110 | Nursing - Permanent Services | 4,000 |
| G9510-66411 | Debt - Bond Interest | 134,000 |
| G9510-66416 | Debt - Bond Princ. - Town | 204,000 |
| G9520-66416 | Debt - Bond Princ. - BOE | 16,000 |
| G9600-63492 | Contingency | 50,000 |
| | TOTAL | <u>803,000</u> |

The funds being transferred are certified as available and unobligated.

Motion carried 8/0.

Supplemental Budget Appropriation & Fund Balance Transfer

MOTION By Barbara Rossi
seconded by Marc Weinberg
to adopt the following resolution:

RESOLUTION CONCERNING A SUPPLEMENTAL BUDGET APPROPRIATION AND FUND BALANCE TRANSFER TO FUND A YEAR-END DEFICIT IN THE PUBLIC WORKS GENERAL FUND ACCOUNTS FOR THE FISCAL YEAR ENDING JUNE 30, 2014

WHEREAS, Town of East Hartford Public Works overtime and facility related expenses are paid from the Town's General Fund, and

WHEREAS, higher overtime and fuel for equipment, predominately related to the severe winter, and water utilities were paid from the Public Works budget, and

WHEREAS, although the Town instituted a department wide budget freeze to offset higher operating costs, it is necessary for the Town of East Hartford to set aside additional budget contributions to fund a projected General Fund deficit in fiscal year 2013-2014.

NOW THEREFORE BE IT RESOLVED, that the East Hartford Town Council does hereby approve this Supplemental Budget Appropriation of funds in the amount of \$767,000 from the Town's Undesignated Fund Balance for the purpose of funding a fiscal year 2013-2014 deficit as listed below and does hereby amend the current 2013-2014 fiscal year Operating Budget to reflect the addition of the attached Supplemental Revenue Appropriation and Expenditure Appropriation.

| | | |
|-------------|---------------------------------|---------|
| G0320-55900 | Fund Balance Appropriation | 767,000 |
| G7300-60141 | Public Works Highway - Overtime | 767,000 |

Funds certified as unobligated and available.

On call of the vote, motion carried 8/0.

CT Brownfields Grant Application

MOTION . By Linda Russo
seconded by Anita Morrison
to adopt the following resolution:

WHEREAS, the Connecticut Department of Economic and Community Development has made funds available for the assessment and remediation of environmentally compromised properties, known as Brownfields; and

WHEREAS, assessment and remediation of these properties protects the environment, reduces blight, and takes development pressures off greenspaces and working lands.

NOW THEREFORE LET IT BE RESOLVED; That Marcia A. Leclerc, Mayor of the Town of East Hartford, is authorized to make application to, and execute and approve on behalf of this corporation, any and all documents, contracts, and amendments as may be required by the Department of Economic and Community Development as they pertain to this Brownfields Grant Program.

On call of the vote, motion carried 8/0.

Library Services and Technology Act Grant

MOTION . By Marc Weinberg
seconded by Linda Russo
to adopt the following resolution:

WHEREAS the Connecticut State Library has awarded the East Hartford Public Library a Library Services and Technology Act (LSTA) Grant and;

WHEREAS the LSTA promotes access to information resources provided by all types of libraries throughout Connecticut

NOW THEREFORE LET IT BE RESOLVED; that Marcia A. Leclerc, Mayor of the Town of East Hartford, is authorized to make application to, and execute and approve on behalf of this corporation, any and all documents, contracts, and amendments as may be required by the Connecticut State Library as they pertain to this Library Services and Technology Act grant.

On call of the vote, motion carried 8/0.

Historic Document Preservation Grant

MOTION By Ram Aberasturia
seconded by Barbara Rossi
to adopt the following resolution:

RESOLVED: That Marcia A. Leclerc, Mayor, is empowered to execute and deliver in the name of and on behalf of this municipality, a contract with the Connecticut State Library for a Historic Preservation Grant.

On call of the vote, motion carried 8/0.

NCAAA Grocery Delivery Grant

MOTION By Linda Russo
seconded by Barbara Rossi
to adopt the following resolution:

WHEREAS the North Central Area Agency on Aging (NCAAA) has offered the Town of East Hartford supplemental funding for the grocery delivery to elderly residents program; and

WHEREAS these additional funds will increase the number of grocery deliveries available to elderly residents of East Hartford.

NOW THEREFORE LET IT BE RESOLVED; that Marcia A. Leclerc, Mayor of the Town of East Hartford, is authorized to make application to, and execute and approve on behalf of this corporation, any and all documents, contracts, and amendments as may be required by the NCAAA as they pertain to securing supplemental funding for a grocery delivery to elderly residents program for the current NCAAA program year.

On call of the vote, motion carried 8/0.

Youth Services Bureau Grant

MOTION By Ram Aberasturia
seconded by Anita Morrison
to adopt the following resolution:

WHEREAS, the Connecticut Department of Education has made available funding through the Youth Service Bureau Grant Program; and

WHEREAS, the purpose of this program is to assist municipalities (or private agencies serving youth which are designated to act as agents for such municipalities), in establishing, maintaining or expanding such Youth Service Bureaus.

NOW, THEREFORE, LET IT BE RESOLVED that Marcia A. Leclerc, Mayor of the Town of East Hartford, is hereby authorized to execute on behalf of this municipality a grant application to the State of Connecticut Department of Education for a "Youth Service Bureau Grant" and to file any amendments or reports as may be required to successfully complete the terms of the grant contract.

BE IT FURTHER RESOLVED that That Marcia A. Leclerc is currently serving as Mayor of the Town of East Hartford. Her term of office began on January 10, 2013 and will continue until November 9, 2015. As the Mayor, Marcia A. Leclerc serves as the Chief Executive Officer for the Town of East Hartford, and is duly authorized to enter into agreements and contracts on behalf of the Town of East Hartford.

On call of the vote, motion carried 8/0.

Youth Services Prevention Grant

MOTION By Ram Aberasturia
seconded by Linda Russo
to adopt the following resolution:

WHEREAS the Town of East Hartford (Youth Task Force) has been identified In Public Act 14-47, Sec. 1 to be a recipient of a \$85,200 grant from the State of Connecticut for the provision of preventive youth services; and

WHEREAS as a condition of the grant, the Town is required to provide documentation that details a plan for spending, monitoring, and reporting on these funds in a manner that is consistent with the intent of the Public Act.

NOW THEREFORE LET IT BE RESOLVED that Marcia A. Leclerc, Mayor of the Town of East Hartford, is authorized to make application to, and execute and approve on behalf of this corporation, any and all documents, contracts, and amendments as may be required by the state Office of Policy and Management as they pertain to this Youth Services Prevention grant.

On call of the vote, motion carried 8/0.

Public Health Emergency Preparedness Grant

MOTION By Marc Weinberg
seconded by Linda Russo
to adopt the following resolution:

WHEREAS, The Connecticut Department of Public Health has offered supplemental funding to extend the Public Health Preparedness Grant an additional year.

NOW THEREFORE LET IT BE RESOLVED that Mayor Marcia A. Leclerc has been empowered to make, execute and approve on behalf of this corporation any and all contracts or amendments thereof with the State of Connecticut Department of Public Health to fund a \$54,652 "Public Health Preparedness" grant for the period July 1st 2014 through June 30th 2015.

On call of the vote, motion carried 8/0.

Outdoor Amusement Permit Applications:

KB Memorial Criterium Bicycle Race

MOTION By Linda Russo
seconded by Esther Clarke
to **approve** the outdoor amusement permit application entitled "Keith Berger Memorial Criterium Bicycle Race/CT Championships", submitted by Massimiliano Accaputo, Race Director, for the TWZ Masters Racing Team, to conduct a series of bicycle races on Sunday, June 22, 2014 from 8:30AM to 3:30PM from Founders Plaza and the following streets: East River Drive, Pitkin Street, Meadow Street, and Hartland Street; subject to compliance with adopted codes and regulations of the State of Connecticut, the Town of East Hartford, and any other stipulations required by the Town of East Hartford or its agencies; and to waive the

US Fish and Wildlife

MOTION By Marc Weinberg
seconded by Barbara Rossi
to waive the \$20.00 application fee due from the Department of the Interior – U. S. Fish and Wildlife Service for the use of a generator at Riverfest as the U.S. Fish and Wildlife Service is a government agency.
Motion carried 8/0.

Board of Education/Town Shared Services:

Presentation by Blum, Shapiro

Vanessa Rossitto, Partner at Blum Shapiro, introduced Jeffery Ziplow, Consulting Partner at Blum Shapiro, who explained that shared services provides an opportunity to create better efficiency and transparency in government. Additionally, creating a shared services environment gives the town and the Board of Education an immediate back-up system for the different departments involved, i.e., payroll, accounts payable, purchasing, IT, Human Resources, etc.

Referral for Study and Action on Shared Services to the Joint Board of Education/Town Council Shared Services Committee

MOTION By Ram Aberasturia
seconded by Barbara Rossi
to adopt the following resolution:

Whereas, the East Hartford Town Council adopts a budget consisting of appropriations for both town and Board of Education services; and

Whereas, the East Hartford Board of Education adopts its own budget allocating funds from the town, the state and federal government and private grant sources; and

Whereas, both town and school budgets have appropriations for funding that affect services and programs by town and school administrations; and

Whereas, what is most important for the citizens of the town of East Hartford is that services are provided in the most cost efficient and effective manner; and

Whereas, the citizens of town of East Hartford further expect that the town and the Board of Education will work collaboratively.

Now therefore be it resolved that the Town Council will work collaboratively with the Board of Education and the Mayor to ensure that vital school and town programs are provided to the citizens of the town in the most cost effective manner and that such collaboration shall include regular joint meetings with the Board of Education and the Mayor especially during budget deliberations and final budget appropriations in order to ensure that all parties fully understand the demands of both the town and school services.

It is further resolved that the Town Council shall refer the specific issue of increasing shared services and efficient town and board services to the Budget Committee which shall work with the Board of Education and the Mayor to develop a collaborative process on shared services.

On call of the vote, motion carried 8/0.

OPPORTUNITY FOR COUNCILLORS TO DIRECT QUESTIONS TO THE ADMINISTRATION

None

COUNCIL ACTION ON EXECUTIVE SESSION MATTERS

Debbie Ahern vs Town of East Hartford

MOTION By Barbara Rossi
seconded by Marc Weinberg
to accept Corporation Counsel's recommendation to settle the pending superior court action known as *Debbie Ahern v. Town of East Hartford*, Docket No. HHD-CV-12-6030791S, for the total of \$16,000.00 as full and final settlement.
Motion carried 8/0.

OPPORTUNITY FOR RESIDENTS TO SPEAK

Mary Symkowicz, 805 Tolland Street, and Lisa Murzin, 97 Winding Lane, were concerned about the handicapped accessibility of the pool at McAuliffe Park where the special education camp has been relocated for the summer.

Mayor Leclerc (1) stated that four of the five pools in East Hartford are fully ADA compliant and the fifth pool is just one step away from being ADA compliant; (2) reviewed the challenges the Parks and Recreation Department faced regarding the use of town pools when the Board of Education made some changes to their summer camp schedule; (3) announced that Wickham Library is fully re-landscaped – thanks to town staff and Goodwin College; and (4) the Mayor met with the Superintendent of Schools and the YMCA to further discuss the utilization of schools/pools for after-school programs.

Rich Kehoe asked that the Mayor keep the Council informed on how ADA equipment will be used in town pools.

Pat Harmon stated that special needs children react to changes much differently than other children and that should be a major consideration when rescheduling programs.

Marc Weinberg wished Lisa Murzin a Happy Birthday.

ADJOURNMENT

MOTION By Esther Clarke
seconded by Ram Aberasturia
to adjourn (9:59 p.m.).
Motion carried 8/0.

The Chair announced that the next meeting of the Town Council would be on July 15th.

Attest Angela M. Attenello
Angela M. Attenello
TOWN COUNCIL CLERK



TOWN OF EAST HARTFORD OFFICE OF THE MAYOR

DATE: July 9, 2014
TO: Members of the Town Council
FROM: Mayor Marcia A. Leclerc 
RE: COMMUNICATION: \$19.1 Million Negotiated GO Bond Placement – TD Bank

Attached is a memo from Michael Walsh, Finance Director, with information regarding \$19.1 million of General Obligation Bonds sold to TD Bank.

Please add the attached to the Town Council agenda for July 15, 2014.

C: M. Walsh, Finance Director



MEMORANDUM

DATE: June 19, 2014

TO: Marcia A. Leclerc, Mayor

FROM: Michael P. Walsh, Director of Finance 

TELEPHONE: (860) 291-7246

RE: **\$19.1 Million Negotiated GO Bond Placement - TD Bank**

On Tuesday, June 17, 2014, the Town of East of Hartford completed the sale of \$19.1 million of General Obligation (GO) Bonds in a negotiated sale to TD Bank.

The proceeds of the sale will be used as follows:

\$5,000,000 2012 Roads
\$4,000,000 2011 Levees
\$7,000,000 2010 Roads
\$2,100,000 2008 Library
\$ 840,000 2006 Firehouse

Because we negotiated this sale (as opposed to a competitive sale), attached please find a letter produced by IBIC detailing comparisons between a direct purchase and a competitive sale.

What you should take away from the letter is based on the existing bond market, the size of the issue, the attractive rate we secured, and the savings both in issuance costs and the cost avoidance of preparing and printing an official statement coupled with the cost to have a bond ratings agency rate our debt, East Hartford benefited in a material way.

I would respectfully ask that this correspondence be forwarded to the Town Council as a communication. Please let me know if you have any questions.

cc: Joseph Carlson, Town Treasurer



June 19, 2014

Mr. Michael Walsh
 Finance Director
 Town of East Hartford
 740 Main Street
 East Hartford, CT 06108

RE: Comparison of TD Bank Direct Purchase to Competitive Sale Market

Dear Mike,

As requested, I have prepared this memorandum in connection with the direct purchase of the Town's \$19,100,000 General Obligation Bonds by TD Bank. We have reviewed the rate supplied by TD Bank (2.12%) and found it be consistent with rates on similar sized and structure issues which have recently sold in the competitive market. Specifically, please see the comparison below:

| | East Hartford | | Londonderry School District, NH | | Sun Prairie, WI | | State of Florida Bd of Gov University System | | Bettendorf, IA | |
|----------------------|--------------------|-------|---------------------------------|-------|--------------------|-------|--|-------|--------------------|-------|
| Sale Date | 6/10/14 | | 6/17/14 | | 6/17/14 | | 5/7/14 | | 4/1/14 | |
| Sale Type | Direct Placement | | Competitive Sale | | Competitive Sale | | Competitive Sale | | Competitive Sale | |
| Amount | \$19,100,000 | | \$3,895,000 | | \$5,970,000 | | \$23,945,000 | | \$4,000,000 | |
| Maturity | 7/15 & 1/15 | | 15-Jul | | 1-Feb | | 1-Jul | | 1-Jun | |
| Security Type | General Obligation | | General Obligation | | General Obligation | | Revenue | | General Obligation | |
| Bank Qualified | No | | Yes | | No | | No | | No | |
| Ratings: | | | | | | | | | | |
| Moody's | n/a (Aa2) | | Aa2 | | Aa2 | | Aa2 | | Aa2 | |
| S&P | | | | | | | AA | | | |
| Fitch | | | | | | | AA | | | |
| Calendar Year | Coupon | Yield | Coupon | Yield | Coupon | Yield | Coupon | Yield | Coupon | Yield |
| 2015 | 2.080 | 2.120 | 3.000 | 0.300 | 1.000 | 0.250 | | | | |
| 2016 | 2.080 | 2.120 | 3.000 | 0.400 | 2.000 | 0.400 | 3.000 | 0.460 | 2.000 | 0.450 |
| 2017 | 2.080 | 2.120 | 3.000 | 0.710 | 2.000 | 0.650 | 4.000 | 0.740 | 5.000 | 0.800 |
| 2018 | 2.080 | 2.120 | 3.000 | 1.090 | 2.000 | 1.030 | 5.000 | 1.070 | 5.000 | 1.150 |
| 2019 | 2.080 | 2.120 | 3.000 | 1.350 | 2.000 | 1.400 | 5.000 | 1.380 | 5.000 | 1.500 |
| 2020 | 2.080 | 2.120 | 3.000 | 1.650 | 2.000 | 1.710 | 5.000 | 1.670 | 5.000 | 1.850 |
| 2021 | 2.080 | 2.120 | 3.000 | 1.930 | 2.500 | 2.000 | 5.000 | 1.990 | 5.000 | 2.150 |
| 2022 | 2.080 | 2.120 | 3.000 | 2.080 | 3.000 | 2.250 | 5.000 | 2.190 | 4.000 | 2.400 |
| 2023 | 2.080 | 2.120 | 3.000 | 2.250 | 3.000 | 2.450 | 5.000 | 2.350 | 2.500 | 2.600 |
| 2024 | 2.080 | 2.120 | 5.000 | 2.350 | 3.000 | 2.600 | 3.000 | 2.500 | 3.000 | 2.770 |
| Call Feature | Callable anytime | | Non-callable | | 2021 @ 100% | | 2024 @ 100% | | 2022 @ 100% | |
| Purchaser | TD Bank | | Fidelity Capital | | Raymond James | | PNC Capital Markets | | Raymond James | |
| Avg Life | 5.3750 | | 5.5310 | | 5.9750 | | 6.9722 | | 6.1940 | |
| Effective rate (TIC) | 2.1200% | | 2.1490% | | 2.2980% | | 2.1130% | | 2.1545% | |

All of the included transactions have a similar bond rating to the Town (Moody's – Aa2) and a similar structure. However, a 10 year issue with at least substantially level principal payments for a Aa2 issuer is not overly common so some of the transactions are spread over an eleven week period. I would like to point out that the security on Florida Board of Governor's was a revenue pledge rather than a general obligation (full faith and credit) pledge. Specifically, the payment on the bonds are secured by a first lien on the Capital Improvement Fees levied on every student enrolled in the university system. However, based on 1) the essential service nature of the issuer (State University System); 2) the strength of the pledged revenue; and 3) the underlying credit strength of the university system, the bonds traded like general obligation bonds, as evidenced by the reoffering yields received on the issue.

I would also like to call your attention to the transaction for the Londonderry School District. Londonderry School District is different than East Hartford in that the district does not have direct taxing authority over the property owners within the district and relies on assessments to the Town of Londonderry, NH. This is similar to the statutory framework that exists for Connecticut school districts. Additionally, New Hampshire state law allows school districts to maintain only minimal fund balance and only with voter approval. If approved, local school districts can retain up to 2.5% of their operating budget which can only be used in the case of an emergency or for future tax relief. Generally speaking, these factors would negatively impact a school district's bond rating and ultimately the marketability of its bonds. However, in the case of Londonderry School District, both the district and the Town of Londonderry are rated Aa2 by Moody's, which I believe speaks to the underlying credit strength of the Town of Londonderry. Due to the Town's credit strength, I included the district's transaction in the comparisons. Furthermore, Londonderry does have a concentration in its employment and tax base similar to but albeit smaller than East Hartford's. I would like also like to point out that of the six bids that the district received on its bonds, five were 3.00% or higher. I believe that to be a function of the three things: 1) lack of direct taxing authority for the district; 2) the frequency that the district issues debt (last bond sale was June 2008) and most importantly, 3) the bank qualification of the bonds. In looking at the reoffering yields received on the bonds, it appears that the winning bidder assumed a larger benefit for the bank qualification than the other bidders. The benefit of the bank qualification is demonstrated in the lower reoffering yields seen in the 2021 to 2024 maturities. The lower reoffering yields and ultimately the large spread between the winning and second place bids exemplify the dynamics of the capital markets. On any given day, one investor may be more willing to put their capital at risk than other investors.

Finally, I would like to mention that by undertaking a direct placement with TD Bank, the Town saved approximately \$28,000 in issuance costs.

If you have any questions, please do not hesitate to contact me.

Sincerely,

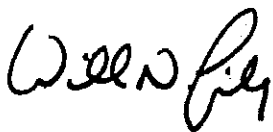

William N. Lindsay
Director



TOWN OF EAST HARTFORD OFFICE OF THE MAYOR

DATE: June 10, 2014
TO: Richard F. Kehoe, Chair
FROM: Mayor Marcia A. Leclerc
RE: TENTATIVE AGREEMENT BETWEEN THE TOWN OF EAST HARTFORD AND THE LOCAL 1174, COUNCIL 4, AFSCME, AFL-CIO UNION

The Town of East Hartford and the Local 1174, Council 4, AFSCME, AFL-CIO Union (hereinafter "Local 1174") entered into a tentative agreement for a new collective bargaining agreement effective July 1, 2012 through June 30, 2017. The tentative agreement was ratified by the bargaining unit members on June 09, 2014.

The impetus for the tentative agreement centered on better controlling health insurance costs for active employees and retirees. During the negotiation process, the Town's goals were to 1) restructure the delivery of health insurance benefits for active Local 1174 union members through a High Deductible Health Plan ("HDHP Plan") paired with a Health Savings Account ("HSA"), 2) introduce a voluntary health screening program, 3) increase the premium cost share for health insurance coverage, and 4) initiate employee contributions into the Town's Other Post Employment Benefit Trust through payroll deductions.

Attached for your review and consideration is a copy of the tentative agreement between the Town of East Hartford and the Local 1174 Union. Mike Walsh, Director of Finance, will prepare and submit to the Council the financial analysis for the five year tentative agreement at the Council meeting scheduled for Tuesday, July 15, 2014

Since this matter involves a need to fund the agreement, the Town's Finance Director and Human Resources Director will be present at the meeting scheduled for July 15, 2014 should there be any questions or concerns or a need to go into executive session.

The attached tentative agreement is being submitted to you within fourteen days from the date the union members ratified the agreement on June 09, 2014. In accordance to Section 7-474 of the General Statutes of the State of Connecticut "Such request shall be considered approved if the legislative body fails to vote to approve or reject such request within thirty days of the end of the fourteen-day period for submission to said body." The end of the thirty day period is July 22, 2014.

I respectfully request that this item be added to the Agenda of the July 15, 2014, Town Council meeting and recommend that the Town Council approve the tentative agreement for the reasons noted above.

Cc: Michael Walsh, Finance Director
Santiago Malave, Human Resources Director

OFFICE OF HUMAN RESOURCES

June 10, 2014

To : Marcia A. Leclerc, Mayor
From : Santiago Malave, Human Resources Director
Re : Local 1174 Union Tentative Agreement



Attached for your review is a suggested transmittal letter to the Council Chairman regarding the Tentative Agreement Between Town of East Hartford and Local 1174, Council 4, AFSCME, AFL-CIO Union (hereinafter "Local 1174 Union") for a successor collective bargaining agreement effective July 1, 2012 through June 30, 2017. The tentative agreement was ratified by the Local 1174 Union members on June 09, 2014.

The impetus for the tentative agreement centered on better controlling health insurance costs for active employees and retirees. During the negotiation process the Town negotiating committee centered on the need to 1) restructure the delivery of health insurance benefits for active Local 1174 Union members through a High Deductible Health Plan ("HDHP Plan") paired with a Health Savings Account ("HSA"), 2) introduce a voluntary health screening program, 3) increase the premium cost share for health insurance coverage, and 4) initiate through payroll deductions employee contributions into the Town's Other Post Employment Benefit Trust.

The tentative agreement with the Local 1174 Union regarding these items achieved the objectives of the Town while keeping within the Town Council's spending directive from the March 2012 joint Town and BOE meeting. Attached for your review is a copy of the tentative agreement.

The tentative agreement needs to be submitted to the Council within fourteen days from the date the union members ratified the agreement, June 09, 2014. In accordance to Section 7-474 of the General Statutes of the State of Connecticut "Such request shall be considered approved if the legislative body fails to vote to approve or reject such request within thirty days of the end of the fourteen-day period for submission to said body." The thirty day period ends on July 22, 2014.

I respectfully request that this item be added to the Council agenda for the June 17, 2014 Council meeting. I also recommend that the Council approve the tentative agreement for the reasons noted above.

Since this matter involves a need to fund the tentative agreement, the Town's Finance Director and I will be present at the meeting scheduled for Tuesday, June 17, 2014 should there be any questions or concerns.

Cc: Mike Walsh

DATE : 06/10/2014

TO : RICHARD F. KEHOE, TOWN COUNCIL CHAIRMAN

FROM : MAYOR MARCIA A. LECLERC

**RE : TENTATIVE AGREEMENT BETWEEN THE TOWN OF EAST
HARTFORD AND THE LOCAL 1174, COUNCIL 4, AFSCME, AFL-
CIO UNION**

The Town of East Hartford and the Local 1174, Council 4, AFSCME, AFL-CIO Union (hereinafter "Local 1174") entered into a tentative agreement for a new collective bargaining agreement effective July 1, 2012 through June 30, 2017. The tentative agreement was ratified by the bargaining unit members on June 09, 2014.

The impetus for the tentative agreement centered on better controlling health insurance costs for active employees and retirees. During the negotiation process, the Town's goals were to 1) restructure the delivery of health insurance benefits for active Local 1174 union members through a High Deductible Health Plan ("HDHP Plan") paired with a Health Savings Account ("HSA"), 2) introduce a voluntary health screening program, 3) increase the premium cost share for health insurance coverage, and 4) initiate employee contributions into the Town's Other Post Employment Benefit Trust through payroll deductions.

Attached to this memorandum is a memorandum from Mike Walsh, Director of Finance, with the financial analysis of the five-year Local 1174 Union tentative agreement. Also, attached for your review is a copy of the tentative agreement between the Town of East Hartford and the Local 1174 Union.

Since this matter involves a need to fund the agreement, the Town's Finance Director and Human Resources Director will be present at the meeting scheduled for Tuesday, June 17, 2014 should there be any questions or concerns or a need to go into executive session.

The attached tentative agreement is being submitted to you within fourteen days from the date the union members ratified the agreement on June 09, 2014. In accordance to Section 7-474 of the General Statutes of the State of Connecticut "Such request shall be considered approved if the legislative body fails to vote to approve or reject such request within thirty days of the end of the fourteen-day period for submission to said body." The end of the thirty day period is July 22, 2014.

I respectfully request that this item be added to the Agenda of the June 17, 2014, Town Council meeting and recommend that the Town Council approve the tentative agreement for the reasons noted above.

Cc: Michael Walsh, Finance Director
Santiago Malave, Human Resources Director

**The Town of East Hartford
-and-
LOCAL 1174 OF COUNCIL 4**

Full Tentative Agreement 04.04.2014

| Year 1 (07.01.2012 – 06.30.2013) | |
|---|--|
| Wages | 2% Retroactive (may be utilized to fund applicable HSA Deductible up to 100% of the annual deductible. Any amount beyond the 100% of the annual deductible will be either placed into the HSA account or paid to the employee according to the employee's election.) |
| Health Insur | No change |
| Year 2 (07.01.2013 – 06.30.2014) | |
| Wages | 2% Retroactive (may be utilized to fund applicable HSA Deductible according to the above.) |
| Health Insur | No change |
| Co-Share | No Change |
| Year 3 (07.01.2014 – 06.30.2015) | |
| Wages | 2% GWI |
| Health Insurance | <p>HSA* Effective July 1, 2014 with 50% upfront Funding of Deductible</p> <p>Employees who retire after the signing of this agreement shall be eligible for the new PPO according to the current contract language parameters.</p> <p>Employees not eligible for the HSA, will have the new PPO at the same premium share as the HDHP.</p> <p>Upon completion of the program, employees who complete the Health Wellness Program (HWP) shall have an additional \$250 contributed to their HSA annually.</p> |
| Co-Share | HSA: 16.25% of premium or Flat dollar amount of F=\$2800, E+1=\$2000, S=\$1500, which-ever is lower. |
| Retiree Insurance | Effective July 1, 2014, employees hired before 2006 will contribute \$250 per year, towards retiree health insurance. |

| Year 4 (07.01.2015 – 06.30.2016) | |
|---|--|
| Wages | 2% GWI |
| Health Insurance | <p>HSA* with 50% upfront Funding of Deductible</p> <p>Employees who retire after the signing of this agreement, shall be eligible for the new PPO according to the current contract language parameters.</p> <p>Employees not eligible for the HSA, will have the new PPO at the same premium share as the HDHP.</p> <p>Upon completion of the program, employees who complete the Health Wellness Program (HWP) shall have an additional \$250 contributed to their HSA annually.</p> |
| Co-Share | HSA: 16.5% of premium or Flat dollar amount of F=\$3200, E+1=\$2200, S=\$1600, which-ever is lower. |
| Retiree Insurance | Effective July 1, 2015 and there-after, employees hired before 2006 will contribute one percent (1%) of their specific base pay towards retiree health insurance. |
| Year 5 (07.01.2016 – 06.30.2017) | |
| Wages | 2% GWI |
| Health Insurance | <p>HSA* with 50% upfront Funding of Deductible</p> <p>Employees who retire after the signing of this agreement shall be eligible for the new PPO according to the current contract language parameters.</p> <p>Employees not eligible for the HSA, will have the new PPO at the same premium share as the HDHP.</p> <p>Upon completion of the program, employees who complete the Health Wellness Program (HWP) shall have an additional \$250 contributed to their HSA annually.</p> |
| Co-Share | <p>HSA: 16.75% of premium or F \$3200, E+1=\$2200, S=\$1600, which-ever is lower.</p> <p>Effective June 30, 2017, premium co-share will be 16.75% of applicable coverage and the cap will no longer be in effect.</p> |
| Retiree Insurance | Employees hired before 2006 shall continue to contribute one percent (1%) of their specific base pay towards retiree health insurance. |

*** HDHP/HSA**

Effective July 1, 2014, the Town, for all eligible employees, shall provide a HDHP (High Deductible Health Plan) and HSA (Health Savings Account) through the Anthem Lumenos plan, with the following deductibles (full summary listed in Appendix ---);

Annual Single Deductible \$1,500
Annual Family Deductible \$3,000

All health insurance costs shall be covered at one-hundred percent (100%) after the applicable annual deductible is reached in the plan year except prescriptions which shall have a co-pay of \$10, 25, 40.

Out-of-Network Deductible:

Annual Out-of-Pocket Maximum Single Deductible \$4,000
Annual Out-of-Pocket Maximum Family Deductible \$8,000

Effective July 1, 2014 and each year thereafter, the Town shall fund fifty percent (50%) of the applicable deductible into the employee's HSA account, on July 1 of that year. The employee shall be required through weekly payroll deduction to fund the remaining fifty percent (50%) of the applicable annual deductible. The Town shall also pay the initial set up fee for the HSA account.

The Town shall provide an additional \$250 contribution to each employees HSA annually upon the completion of the Health Wellness Program (HWP).

Employees who are not eligible for an employer funded HSA, shall be provided insurance coverage through the PPO plan, as outlined below, at the same co-share rate of the HDHP.

New PPO

The Town shall provide a PPO with the following co-payments;

PPO open access plan

| | |
|---------------------------|----------------------------|
| Office visit preventative | \$0 |
| Office visit | \$20 |
| Specialist | \$25 |
| Urgent Care | \$50 |
| Emergency | \$100 (waived if admitted) |
| Outpatient Surgery | \$150 |
| Inpatient | \$250 |

Prescriptions - Retail up to 34 days, Tier I (generic), \$10 copayment; Tier II (listed brand), \$20 copayment; Tier III (non-listed brand), \$30 copayment and;

Mail Order up to 100 days equal to two times co-pay: Tier I (generic), \$20 copayment; Tier II (listed brand), \$40 copayment; Tier III (non-listed brand), \$60 copayment. The annual prescription cap of \$5,000 per person remains.

Additional Contract Language Changes:

Section 3.1 Newly hired employees shall serve a probationary period of **one hundred and twenty (120) work days**, and shall have no seniority rights during this period, but shall be subject to all other provisions of this Agreement. Dismissal of an employee during his probationary period shall not be subject to the grievance procedure. Employees who have completed their probationary periods shall be full-time employees and shall acquire length of service records as of the date of their employment.

Section 3.4 Layoffs shall take effect as follows:

- a. Part-time employees of Local #1174,
- b. Employees working twenty (20) hours a week,
- c. Probationary employees,
- d. Full-time employees with the least seniority in the bargaining unit first, within the classification. A laid off employee shall have bumping rights laterally or downward within the bargaining unit based on his seniority and his ability to perform the job within thirty (30) days of the bumping.

Section 4.3 d.

- d. Overtime opportunities shall be offered to the employee(s) with the lowest amount of charged overtime within classification. Said overtime shall be offered in the order in which it becomes available.

Section 4.3 e.

- e. All employees will be given **three (3) hours'** notice, prior to the completion of their regular work day, when overtime work is to be performed to extend the regular work day. If such notice is not given, there will be no charge as provided for in Section c above.

Section 4.6

- a. Employees may be temporarily assigned, within classification and by Town seniority, to perform work in other departments or divisions, except in the Waste Services Division. Such employees shall work the same work schedules as others regularly performing such work. The Director retains the exclusive right to determine the division or department from which the temporarily assigned employee is chosen.

Section 6.1 The scheduling of vacation periods will be made by the Town, in accordance with the provisions of Sections 6.2 and 6.3, no later than April 15th of the vacation year. The use of individual vacation days will require that a request be made of the Supervisor at least twenty-four (24) hours in advance, under normal circumstances. A quarter-day or half-day vacation can be used during any two (2) or four (4) hour increments during the work day.

Section 6.3 Whenever there shall be a conflict in requested dates, preference will be given to employee according to Town seniority.

Section 7.2 Family Medical Leave: The Town will comply with the terms of the Federal Family Medical Leave Act, as amended from time to time. Summary of some of the current terms of the Act can be found in Appendix ____.

Appendix [INSERT]

Family Medical Leave

The terms of Family Medical Leave include but are not limited to the following:

- a. Under circumstances described below, employees will be eligible for up to 12 weeks of paid or unpaid family and medical leave in a twelve-month period. Pursuant to Federal Law, employees may choose, or employers may require the employee to use, accrued paid leave to cover some or all of the FMLA leave taken. In addition, employees may choose, or employers may require, the substitution of accrued paid vacation or personal leave for any of the situations covered by FMLA.
- b. Events which qualify employees for ~~each~~ up to twelve (12) weeks of unpaid leave are:
 - Birth or adoption of a child or placement of a child in the employee's home for foster care.
 - A serious health condition, as defined by FMLA, of the employee or employee's spouse, employee's parent or child.
 - Any qualifying exigency arising out of the fact that the employee's spouse, child or parent is a covered military member on "covered active duty."
- c. Employees may be eligible for up to twenty-six (26) weeks of leave during a single 12-month period to care for a covered servicemember with a serious injury or illness if the eligible employee is the servicemember's spouse, child, parent, or next of kin (military caregiver leave).
- e.d. To qualify for FMLA leave, employees requesting such leave must explain the reason for the leave in writing to their department head so that the Town can determine if FMLA-qualified leave will be granted.
- e.e. The Town may require medical certification to document the reason for the leave, where provided by law.

- e.f. The Town will notify the employee in writing before the leave begins that the leave has been designated as FMLA leave and will be deducted from the allowable maximum.
- f.g. During the period of FMLA-qualified leave, the employee shall not be credited for length of service and shall not be credited with time for the purpose of accruing sick leave, vacation leave, or Personal Days.
- g.h. During the period of FMLA-qualified leave, the employee shall retain health benefits at the same level as before the leave. The Town will continue to pay the premiums as before the leave. Any employee contributions to health insurance shall be made directly to the Town by the employee.

Section 8.1 - Differentials

- b. The Town agrees to pay all employees required to work on a paving operation a rate of **fifty cents per hour** added to their regular rate for the periods that they are required to work on this job.

Section 10.1

- c. The uniform may consist of the following:
 - Dark Blue Jacket
 - Colored shirt (must meet OSHA Specifications, otherwise, color vest will be warned)
 - Dark Blue Trousers
 - Dark Blue Shorts
 - T-shirt or other equivalent as determined by Department Head. (A total of five (5) t-shirts will be provided to each employee. Employees will assume the responsibility and care for T-shirts).
 - In lieu of the 5 t-shirts provided above, the Department Head shall offer two sweatshirts (hooded and/or non-hooded) **and three (3) t-shirts.**

All styles and types of uniforms shall be determined by Department Head. All employees will wear the issued uniform of the day.

Section 10.2

b. The Town will provide one (1) pair of safety shoes at least ankle high and steel-toed per year in an amount not to exceed \$150 annually and employees will wear *Remainder of section to follow...*

Additional Items:

1. In addition to the negotiated GWI's, effective upon ratification and approval, the Mechanic II position (both 52 Classifications) and the Maintenance Mechanic position (both 50 Classifications) shall receive an additional \$1.00 per hour. The remaining negotiated GWIs shall be applied to those hourly amounts moving forward.

In addition to the negotiated GWI's, effective upon ratification and approval, the Mechanic I position (46 Classification) shall receive an additional \$0.50 per hour to the wage rate in effect at that time. The remaining negotiated GWIs shall be applied to that hourly amounts moving forward.

2. On or about April of 2014, the parties agree to meet and discuss restructuring of the following Classifications (Maintainer I, II, III), Position Upgrades, and Positions:

Parts Garage Clerk: Upgrade from grade 44 to grade 48

Mechanic 1: Upgrade from grade 46 to Mechanic 2 grade 52

Maintainer 3 (Eductor operator): Upgrade from grade 48 to grade 52

Maintainer IV/HEO: Upgrade position

Senior Dike Maintainer: Upgrade from grade 48 to grade 52

Rolloff Driver: Create a Rolloff Driver position grade in sanitation

Laborer: Create a Laborer position grade in Sanitation

Class A Trailer Driver: Create a Class A Trailer position grade in Public Works

Fabricator: Create a Fabricator position grade not to be filled but to be temp promoted to when something needs to be built (leaf boxes and other equipment that can be done in house instead of paying a contractor to build)

Maintenance Mechanic: Fill the third Maintenance Mechanic position grade 50 in the Parks (position exclusively responsible for small engine repair for whole town)

There shall be no additional changes to the Collective Bargaining Agreement other than those that are outlined in this TA or non-substantive changes agreed to upon the drafting of the final CBA.

For the Town of East Hartford

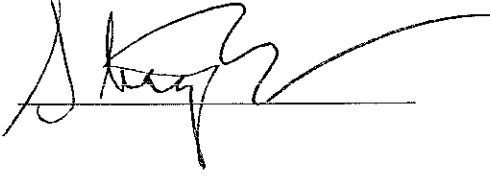

For Local 1174

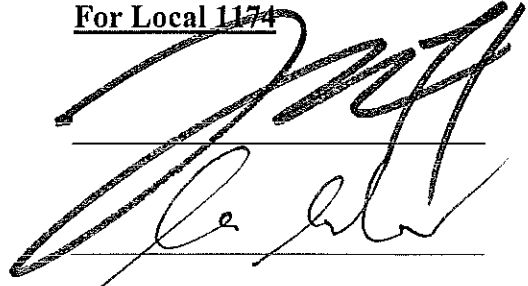



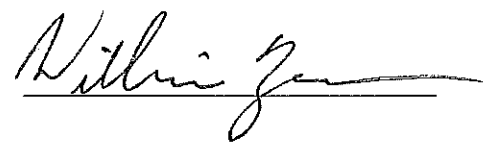

MEMORANDUM OF UNDERSTANDING

The Town of East Hartford ("Town") and Local 1174, Council 4, AFSCME, AFL-CIO ("Union"), hereinafter the Parties ("Parties") agree as follows:

1. The Parties are signatories to a collective bargaining agreement which expired by its own terms on June 30, 2012.

2. The Parties reached a Tentative Agreement on a successor collective bargaining agreement. The Tentative Agreement was submitted to the Union membership for ratification on July 6, 2014.

3. The Union membership did not ratify the Tentative Agreement.

4. In an effort to resolve their differences and to avoid Binding Arbitration, the Parties agree to the following amendments to the Tentative Agreement:

A. Section 8.1(b): Substitute the following language:

The Town agrees to pay all employees, who were hired to work on a paving operation, a rate of one dollar (\$1.00) per hour added to their regular rate for the period that they are required to work on this job.

B. Add the following language to Section 8.2:

An employee permanently promoted into a higher level job classification in accordance with Article VIII, Section 8.4 (b) of the Working Agreement between the Town of East Hartford and Local 1174, may be eligible to receive the top step of pay for the higher level position as follows:

i) The employee was able to demonstrate to the Public Works Director during their temporary promotion period the ability to perform all the tasks, duties and responsibilities assigned within the scope of the job description for the higher level job classification permanently promoted.

C. Effective 7/1/14, employees hired prior to 2006 will not be required to contribute Two Hundred Fifty Dollars (\$250.00) per year toward retiree health insurance.

D. Effective 7/1/15, employees hired prior to 2006 will be required to contribute one percent (1%) of their specific base pay towards retiree health insurance.

The Union will present these changes in the Tentative Agreement as set forth above to the Union membership. If the Union membership rejects the changes set forth herein, the Parties mutually agree and promise that this Memorandum of Understanding or the process of having a second revote on the Tentative Agreement will not be submitted by any Party during the Binding Arbitration proceedings as background evidence to the bargaining history between the Parties or for any other reason.

The Parties hereto sign their agreement with the terms of this Memorandum of Understanding dated this 30 day of May, 2014.

FOR THE TOWN OF EAST HARTFORD

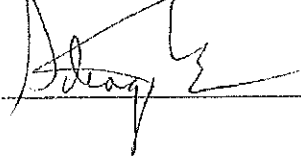
 5/27/14

FOR AFSCME LOCAL #117A

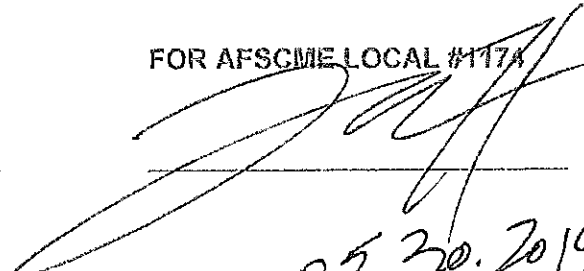
05.30.2014



TOWN OF EAST HARTFORD OFFICE OF THE MAYOR

Date: June 23, 2014
TO: Richard F. Kehoe, Chair
FROM: Mayor Marcia A. Leclerc
RE: Contingency Transfer – 1174 Contract Settlement

Attached is a Contingency Transfer in the amount of \$135,759 that needs Town Council approval to cover costs associated with the latest 1174 Laborer's Contract settlement. Also provided from our Finance Director, is a breakdown and details of these costs.

Please place this item on the Town Council agenda for July 15, 2014.

Town Of East Hartford
Request for Budgetary Transfer of Funds

Department Name CONTINGENCY
Fund Name General

Fiscal Year 2014-2015

Date July 15, 2014
Fund Number GO1

| To: Account No. | Account Name | Amount | From: Account No. | Account Name | Amount |
|-----------------------|--------------|------------|---------------------|--------------|------------|
| Highway - Perm. Serv. | G7300-60110 | \$ 58,000 | Contingency Reserve | G9600-60201 | \$ 135,759 |
| Waste - Perm. Serv. | G7400-60110 | \$ 26,000 | Contract Neg | | |
| Fleet - Perm. Serv. | G7700-60110 | \$ 15,000 | | | |
| Bldg. Perm. Serv. | G7800-60110 | \$ 6,000 | | | |
| Parks - Perm. Serv. | G8200-60110 | \$ 30,759 | | | |
| | | | | | |
| | Total | \$ 135,759 | | Total | \$ 135,759 |

JUSTIFICATION: Provide detail and specific reasons for this transfer.

This should include future budget impact on both the "to" and the "from" accounts. Attach additional information if necessary.

To provide a source of funds to settle the 1174 contract retroactivity for the fiscal years ending June 30, 2013 and 2014.

Signature- Director/Department Head *Keith*

Approvals *[Signature]*

Finance Director

6/19/14
Date Approved

Mayor

Date Approved

Town Council/Clerk

Date Approved

Finance DEPARTMENT USE ONLY

Transfer _____

Date Entered _____

Entered By _____



MEMORANDUM

DATE: June 19, 2014

TO: Marcia A. Leclerc, Mayor

FROM: Michael P. Walsh, Director of Finance 

TELEPHONE: (860) 291-7246

RE: 1174 Contract Settlement - Contingency Transfer

By way of this memo, let me respectfully request a Contingency Transfer to cover the settlement costs of the recently negotiated 1174 Laborer's Contract.

The funding being requested will pay for the retroactivity for the July 1, 2012 through June 30, 2013 and July 1, 2013 through June 30, 2014 fiscal years.

The FY 15 budget was preloaded with the actual settlement wages so no changes need to be made to the upcoming budget.

A total of \$135,759 is needed to cover the cost to implement the agreement. A transfer sheet is provided and requires Town Council action.

Please contact me if you have any questions or problems on any of the aforementioned information.

The Town of East Hartford
 Analysis of the 1174 Contract
 Prepared as of June 12, 2014

| | | |
|--------|---------------|-----------------|
| Actual | Wages | Prem. Share |
| | 2, 2, 2, 2, 2 | Convert to HDHP |

Employees Covered 60

| | Base | Precon. | Year 1 | | Year 2 | | Year 3 | | Year 4 | | Year 5 | | |
|------------|-----------|---------|------------|--------|------------|--------|------------|--------|------------|--------|------------|--------|------------|
| | @6/30/012 | GW1 | 6/30/12 | @7/12 | 6/30/13 | @7/13 | 6/30/14 | @7/14 | 6/30/15 | @7/15 | 6/30/16 | @7/16 | |
| | | 0.00% | Base Total | 2.00% | Base Total | 2.00% | Base Total | 2.00% | Base Total | 2.00% | Base Total | 2.00% | Base Total |
| Reg. Wages | 2,860,368 | - | 2,860,368 | 57,207 | 2,917,575 | 58,352 | 2,975,927 | 59,519 | 3,035,445 | 60,709 | 3,096,154 | 61,923 | 3,158,077 |
| OT Wages | 500,000 | - | 500,000 | 10,000 | 510,000 | 10,200 | 520,200 | 10,404 | 530,604 | 10,612 | 541,216 | 10,824 | 552,040 |
| Total | 3,360,368 | - | 3,360,368 | 67,207 | 3,427,575 | 68,552 | 3,496,127 | 69,923 | 3,566,049 | 71,321 | 3,637,370 | 72,747 | 3,710,118 |

| Year | Wage Inc. Per Year | Wage Inc. Total |
|-------|--------------------|-----------------|
| Pre | - | - |
| 1 | 67,207 | 67,207 |
| 2 | 68,552 | 135,759 |
| 3 | 69,923 | 205,681 |
| 4 | 71,321 | 277,002 |
| 5 | 72,747 | 349,750 |
| Total | | 1,035,400 |

| Total Per Year | Total Per Contract | Net Med. Decrease | Ann. Net Increase | Net Increase | % Inc. Ann. |
|----------------|--------------------|-------------------|-------------------|--------------|---|
| - | - | - | - | - | 0.00% |
| 67,207 | 67,207 | - | 67,207 | 67,207 | 1.98% |
| 68,552 | 135,759 | - | 68,552 | 135,759 | 1.98% |
| 69,923 | 205,681 | 186,077 | (116,155) | 19,604 | -3.29% HDHP conversion, cap lift, OPEB |
| 71,321 | 277,002 | 44,933 | 26,388 | 232,069 | 0.75% cap lift process taking place, OPEB |
| 72,747 | 349,750 | - | 72,747 | 349,750 | 2.06% cap removal/to 16.75%, OPEB |
| 349,750 | 1,035,400 | 231,010 | 118,739 | 804,390 | 3.48% |

| HDHP | | 16.25% |
|---------------|--------|--------|
| Single | 7,438 | 1,209 |
| Single plus 1 | 14,876 | 2,417 |
| Family | 20,083 | 3,263 |
| Blended rate | 17,256 | 2,804 |

| PPO | Cost | 14% | Cap |
|---------------|--------|-------|-------|
| Single | 9,359 | 1,310 | 1,836 |
| Single plus 1 | 18,718 | 2,621 | 1,836 |
| Family | 25,238 | 3,533 | 1,836 |
| Blended rate | 21,694 | 3,037 | 1,836 |

| "Loss" | Average annual increase | | |
|--------|-------------------------|------------|------------|
| | Year 3 Cap | Year 4 Cap | Year 5 Cap |
| - | 1,500 | 1,600 | 1,600 |
| 784 | 2,000 | 2,200 | 2,200 |
| 1,697 | 2,800 | 3,200 | 3,200 |
| 1,201 | 2,430 | 2,740 | 2,740 |

0.70%

| | |
|-----------------------------|--------|
| Town cost of the PPO | 18,657 |
| Town cost of the HDHP | 14,452 |
| Savings | 4,205 |
| 50% ded. Seed plus Wellness | 1,750 |
| Net savings | 2,455 |

| | | | | |
|------------------------------|---------|---------|---------|---------|
| Capped premium share revenue | 107,019 | 145,800 | 164,400 | 164,400 |
| OPEB Contribu. | | - | 26,333 | 26,333 |



TOWN OF EAST HARTFORD OFFICE OF THE MAYOR

DATE: July 7, 2014
TO: Richard F. Kehoe, Chair
FROM: Mayor Marcia A. Leclerc 
RE: RESOLUTIONS – Energy Performance Contract III – Ameresco, Inc.

Attached is a memo from Michael Walsh, Finance Director and Timothy Bockus, Director of Public Works, that reviews the previous energy performance contracts totaling \$12.1 million and details what was updated with these funds.

There are two Resolutions included, that if approved by Town Council, will allow the town to continue to upgrade our Emergency Operations Plan capital improvements. As mentioned in the Resolutions, because of the energy savings that will be seen with these improvements, there will be no additional cost to the town or East Hartford taxpayers. The request is to enter into an Energy Savings Performance Contract with Ameresco, Inc., or its affiliates not to exceed \$4.2 million.

Please place this information and the attached two Resolutions on the July 15, 2014 Town Council agenda.

Thank you.

C: M. Walsh, Finance Director
T. Bockus, Public Works Director



MEMORANDUM

DATE: July 3, 2014

TO: Marcia A. Leclerc, Mayor

FROM: Michael P. Walsh, Director of Finance
Tim Bockus, Director of Public Works

TELEPHONE: (860) 291-7246 or (860) 291-7372

RE: Energy Performance Contract III - Ameresco, Inc.

Perhaps the best place to start this discussion is to recall Storm Alford which hit East Hartford on October 29, 2011 causing widespread power outages which lasted for nearly a week.

During this natural disaster, East Hartford executed its Emergency Operations Plan (EOP) which included opening shelters and distributing food. Although East Hartford made it through the event better than most communities comparatively, after the event, a thorough assessment of the town's response was conducted and improvements were identified.

Opportunities to be better prepared in the future (important given we are the host site for Montville and Waterford in the event of an issue at the Millstone Power Plant) include improving the reliability of facilities and infrastructure through the addition of pad mounted generators at the High School and Middle School. Although we have applied for a grant to add this type of redundancy to our EOP, no award is imminent.

Additionally, the introduction of a trailer mounted generator that can connect to either one of two centrally located schools, both of which have gymnasium space for cots, shower facilities, and cooking facilities would also provide our EOP with scalability and flexibility.

In order to provide a funding source sufficient to procure the items necessary to expand and improve on our EOP as discussed above, a retrofit of the Town's streetlights moving from high pressure sodium fixtures to LED (light emitting diodes) fixtures was selected as the primary energy savings contract component when coupled with an Energy Performance Contract.

If you recall, East Hartford has completed two previous energy performance contracts totaling \$12.1 million whereby the premise is to replace certain equipment/fixtures with newer, more energy efficient equipment/fixtures so that the energy and maintenance savings over the life of the financing can be used to pay for the cost of improvement without any capital investment by the Town or its taxpayers.

With respect to this EPC, the savings generated from reduced electricity consumption (60%) and lower maintenance costs (40%) that are associated with a more efficient light fixture will be used to pay for the retrofit of 5,000 streetlight fixtures and provide for the items to improve our EOP which were discussed above and further detailed below.

Accordingly, by way of this memo, attached please find a resolution to allow the Mayor to enter into an Energy Performance Contract with Ameresco, Inc. to complete the following:

1. The conversion of approximately 5,000 streetlights to LED
2. The replacement of 50% of the downtown decorative street lights
3. The replacement of lighting fixtures at the Community Cultural Center apartments
4. The installation of two pad mounted generators; one at EHHS and one at the EHMS
5. The purchase of a trailer mounted generator
6. The installation of universal generator connections at Sunset Ridge and Hockanum
7. The purchase of a pad mounted generator for EHHA - Hockanum Community Center
8. The replacement of external lighting fixtures on various Town buildings

A second resolution is also attached which provides the approval of the Town Council to enter into a municipal tax-exempt lease purchase financing with Bank of America. Bank of America was selected as the financing vendor due to their low rate and extensive experience underwriting energy performance contracts.

Both resolutions must be approved by the Town Council in order for the Town to continue with this project. Representatives from Ameresco, Inc. will be on hand for the July 15th Town Council meeting to discuss the retrofit and any other items related to the contract.

I have attached a cash flow based on the amount expected to be expended and financed by the town compared to the annual savings in the electricity and the maintenance of the new fixtures. When coupled together, the savings provides the funding source to complete this project without increasing costs to the East Hartford taxpayer.

Please be advised that East Hartford Fire Chief John Oates will be on hand to briefly review the EOP and how the generators will provide reliable sheltering to our citizens. East Hartford Police Chief Scott Sansom will also be on hand to briefly discuss the characteristics of LED lighting and how the white light provided by LEDs is beneficial to law enforcement in the field.

Should you have any questions or problems on the aforementioned, please feel free to contact me.

cc: Fire Chief John Oates
Police Chief Scott Sansom

RESOLUTION CONCERNING AN ENERGY SAVINGS PERFORMANCE CONTRACT

WHEREAS, the Town of East Hartford, working through the Request for Proposal process, has selected Ameresco, Inc. to identify energy and maintenance savings opportunities related to streetlights and other fixtures in town, and

WHEREAS, Ameresco, Inc. and their engineers have identified approximately \$4.2 million of energy related facility improvement measures including streetlight fixtures that will generate approximately \$6.6 million of total budget savings over the 15 year life of the contract and financing through direct energy savings, maintenance savings, and utility rebates, and

WHEREAS, the total budget savings generated under this energy savings performance contract with Ameresco, Inc. will allow the town to secure much needed Emergency Operations Plan capital improvements and through lease financing, to issue debt over a period of 15 years whereby the debt service will be paid completely by the savings generated under this contract, resulting in no net cost increase to the Town budget or East Hartford taxpayers.

NOW THEREFORE BE IT RESOLVED, that the Mayor of the Town of East Hartford is authorized to enter into an Energy Savings Performance Contract with Ameresco, Inc. or its affiliates not to exceed \$4.2 million. The contract terms, payment schedule, and other details of the contract shall be mutually determined between the company and the Mayor, whose signatures will indicate approval of specific terms and conditions.

I, Angela Attenello, Clerk of the Town Council of the Town of East Hartford, certify that the above resolution was approved at a meeting of the Town Council held on July 15, 2014.

Angela Attenello, Clerk of the Town Council

**RESOLUTION TO AUTHORIZE A MUNICIPAL TAX-EXEMPT
LEASE PURCHASE FINANCING AGREEMENT**

WHEREAS, the Town of East Hartford intends to purchase various capital equipment under a Energy Savings Performance Contract with Ameresco, Inc. and/or its affiliates, and

WHEREAS, the cost of the various capital equipment is \$4.2 million; and

WHEREAS, the Town is expected to save through direct energy savings, maintenance savings, and utility rebates \$6.6 million in total over the next 15 years and will use those savings to pay principal and interest on the borrowing.

THEREFORE BE IT RESOLVED, that the Mayor of the Town of East Hartford is authorized to enter into a lease purchase agreement and related documents with Bank of America and/or its affiliates in an amount not to exceed \$4.2 million. The interest rate, payment schedule and other details of the financing shall be mutually determined between the company and the Mayor, whose signatures will indicate approval of specific terms and conditions.

BE IT FURTHER RESOLVED, that the Town declares its intent to be reimbursed for any temporary advances from the General Fund to pay for any part of the equipment from proceeds of the lease financing in accordance with Treasury Regulation 26 CFR 1.103-18 and/or 26CFR1.150-2.

I, Angela Attenello, Clerk of the Town Council of the Town of East Hartford, certify that the above resolution was approved at a meeting of the Town Council held on July 15, 2014.

Angela Attenello, Clerk of the Town Council

Town of East Hartford, CT
Project Savings Summary

| Ecm # | ECM Name | Annual kW | Total kWh | Energy Savings | O&M Savings | Total Project Savings | Total Project Costs | SPB |
|-------|--|-----------|-----------|----------------|-------------|-----------------------|---------------------|--------|
| 1 | Street Lighting Upgrades | - | 1,499,673 | \$ 177,111 | \$ 120,000 | \$ 297,111 | \$ 1,893,507 | 6.37 |
| 2 | Downtown Lighting Upgrades | - | 38,085 | \$ 4,498 | \$ - | \$ 4,498 | \$ 1,059,680 | 235.60 |
| 3 | Community Center Lighting Upgrades | 64 | 13,600 | \$ 2,187 | \$ - | \$ 2,187 | \$ 37,526 | 17.16 |
| 4 | High School Emergency Generator | - | - | \$ - | \$ - | \$ - | \$ 399,322 | - |
| 5 | Middle School Emergency Generator | - | - | \$ - | \$ - | \$ - | \$ 303,118 | - |
| 6 | Sunset Ridge/Hockanum Elementary Emergency Generator | - | - | \$ - | \$ - | \$ - | \$ 268,472 | - |
| 7 | Housing Authority Community Center Emergency Generator | - | - | \$ - | \$ - | \$ - | \$ 99,275 | - |
| 8 | Exterior Lighting Upgrades | - | 114,262 | \$ 18,374 | \$ - | \$ 18,374 | \$ 109,835 | 5.98 |
| | | 64 | 1,665,620 | \$ 202,171 | \$ 120,000 | \$ 322,171 | \$ 4,170,735 | 12.95 |

Town of East Hartford, CT - Pro-Forma

| Initial Project Costs: | |
|--|---------------------|
| Implementation costs | \$ 4,170,735 |
| Total Initial Project Costs | \$ 4,170,735 |
| | |
| | |
| | |
| | |
| | |
| Net Project Costs after rebates | \$ 4,170,735 |

| Financial Assumptions | |
|--|----------|
| Term of Project (yrs) | 15.0 yrs |
| Term of Financing (yrs) | 14.5 yrs |
| Estimated Financing Rate | 2.97% |
| | |
| Payments per year (frequency) | 2 |
| Discount Rate | 2.97% |
| | |
| Average Energy escalation rate(annual) | 3.00% |
| | |
| Project Simple Payback | 12.95 |

| Pro-forma | Initial Values | Year | | | | | | | | | | Totals |
|--|----------------|------------|------------|------------|------------|------------|------------|------------|------------|------------|------------|--------------|
| | | 1 | 2 | 3 | 4 | 5 | 6 | 7 | 8 | 9 | 10 | |
| 1 Annual energy cost savings | \$ 202,171 | \$ 208,236 | \$ 214,483 | \$ 220,917 | \$ 227,545 | \$ 234,371 | \$ 241,402 | \$ 248,644 | \$ 256,104 | \$ 263,787 | \$ 271,700 | \$ 2,387,190 |
| 2 O&M Savings (Year 1 includes utility incentives) | \$ 120,000 | \$ 586,587 | \$ 127,308 | \$ 131,127 | \$ 135,061 | \$ 139,113 | \$ 143,286 | \$ 147,585 | \$ 152,012 | \$ 156,573 | \$ 161,270 | \$ 1,879,923 |
| 3 Total Project Savings | \$ 322,171 | \$ 794,823 | \$ 341,791 | \$ 352,045 | \$ 362,606 | \$ 373,484 | \$ 384,689 | \$ 396,229 | \$ 408,116 | \$ 420,360 | \$ 432,970 | \$ 4,267,113 |
| 4 Payments for financing equipment | \$ - | \$ - | \$ - | \$ - | \$ - | \$ - | \$ - | \$ - | \$ - | \$ - | \$ - | \$ - |
| 5 Payments for Ongoing Services | \$ - | \$ 61,125 | \$ 62,959 | \$ 64,848 | \$ 66,793 | \$ 68,797 | \$ 70,861 | \$ 72,986 | \$ 75,176 | \$ 77,431 | \$ 79,754 | \$ 700,730 |
| 6 Net annual benefits | \$ - | \$ - | \$ - | \$ - | \$ - | \$ - | \$ - | \$ - | \$ - | \$ - | \$ - | \$ - |
| 7 Cumulative cash flow | \$ 300,970 | \$ - | \$ - | \$ - | \$ - | \$ - | \$ - | \$ - | \$ - | \$ - | \$ - | \$ - |
| 8 Net Present Value of cash flow | \$ 194,027 | \$ - | \$ - | \$ - | \$ - | \$ - | \$ - | \$ - | \$ - | \$ - | \$ - | \$ - |
| 9 Interest Rate | 2.97% | | | | | | | | | | | |
| 10 Discount Rate | 2.97% | | | | | | | | | | | |

| Line # | 11 | 12 | 13 | 14 | 15 | Totals |
|--------|------------|------------|------------|------------|------------|--------------|
| 1 | \$ 279,851 | \$ 288,247 | \$ 296,894 | \$ 305,801 | \$ 314,975 | \$ 3,872,959 |
| 2 | \$ 166,108 | \$ 171,091 | \$ 176,224 | \$ 181,511 | \$ 186,956 | \$ 2,761,813 |
| 3 | \$ 445,960 | \$ 459,338 | \$ 473,118 | \$ 487,312 | \$ 501,931 | \$ 6,634,772 |
| 4 | \$ 363,813 | \$ 374,728 | \$ 385,969 | \$ 397,548 | \$ 408,504 | \$ 5,196,949 |
| 5 | \$ 82,147 | \$ 84,611 | \$ 87,150 | \$ 89,764 | \$ 92,457 | \$ 1,136,859 |
| 6 | \$ - | \$ - | \$ - | \$ - | \$ 300,970 | \$ 300,970 |
| 7 | \$ - | \$ - | \$ - | \$ - | \$ 300,970 | \$ 300,970 |
| 8 | | | | | | |
| 9 | | | | | | |
| 10 | | | | | | |

- Notes:
- 1 This Proforma Cash Flow reflects an estimated tax exempt lease rate of 2.97%. The actual rate will increase or decrease based on market conditions and customer credit rating at the time of lease funding.
 - 2 Savings are based on current utility rate structures and usage information provided for purposes of this project.
 - 3 Year 1 O&M savings includes estimated incentives equal to \$462,987

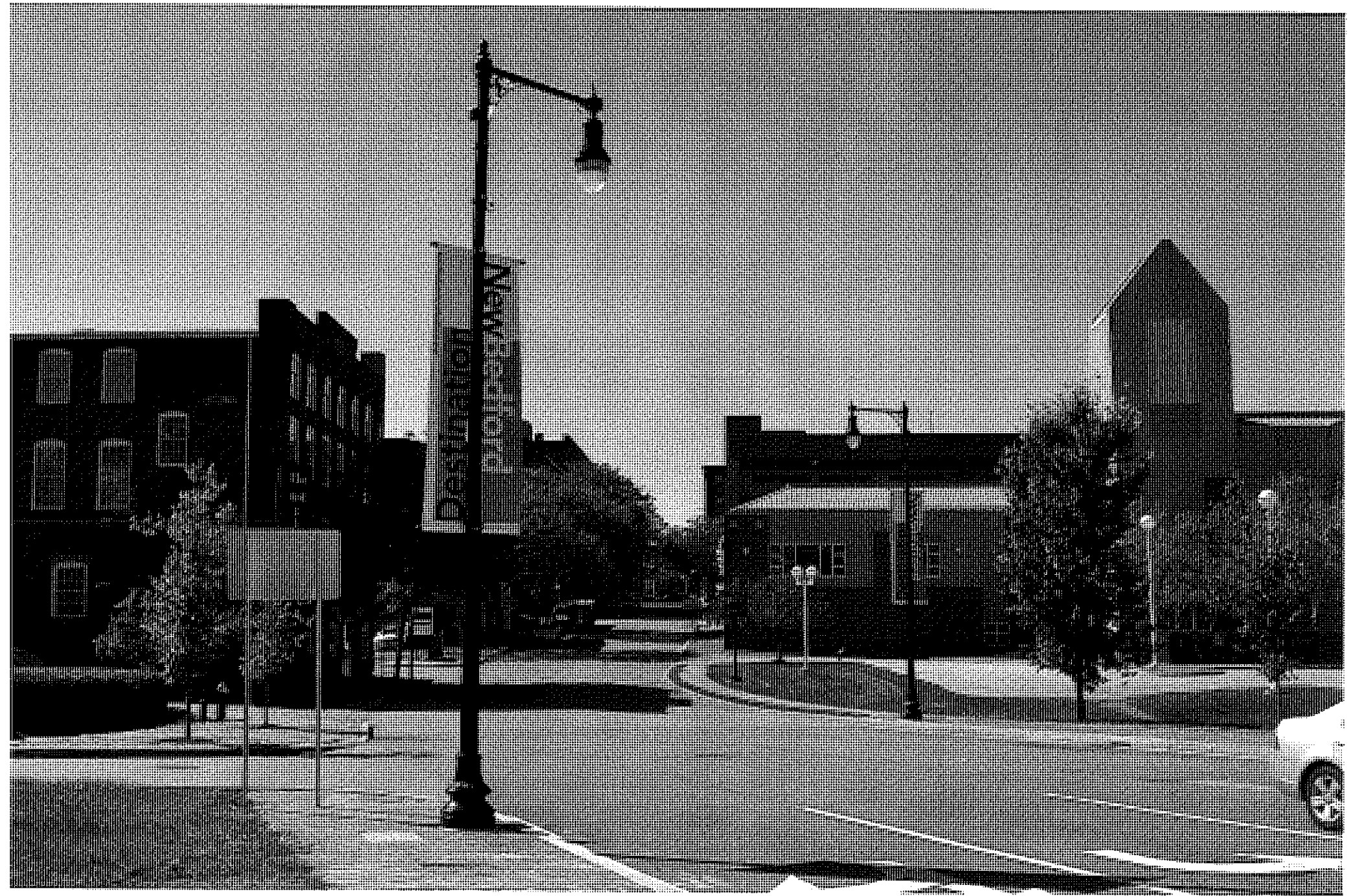

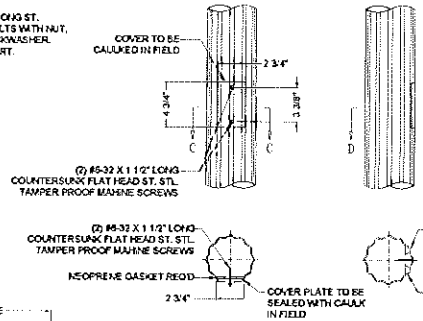
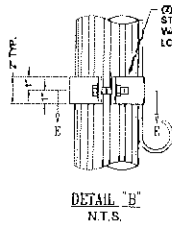
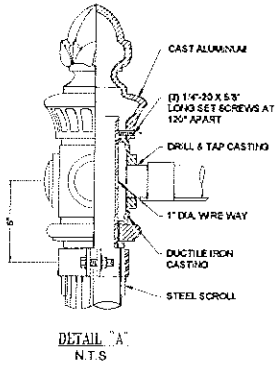

DETAIL 'C'
RECEPTACLE PROVISIONS WITH COVER PLATE
N.T.S.

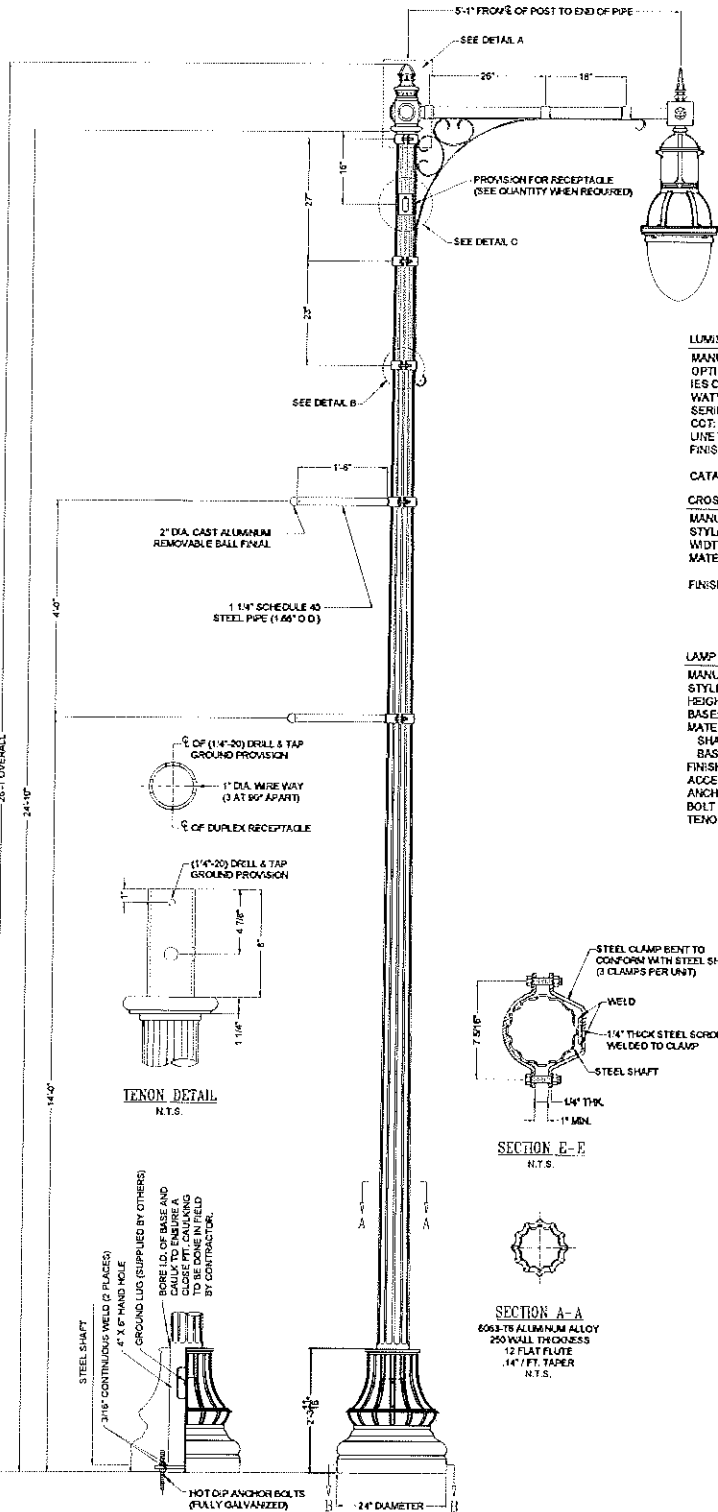

LUMINAIRE SPECIFICATIONS

MANUFACTURER: KING LUMINAIRE
OPTICAL SYSTEM: FLAT ARRAY DEEP R/PPLD
IES CLASS: TYPE II
WATTAGE: 150W LED SOLID STATE LIGHTING
SERIES: B090
CCT: 4500K
LINE VOLTAGE: 120/277V
FINISH: POWDER COATED - GLOSS BLACK

CROSS ARM SPECIFICATIONS

MANUFACTURER: KING LUMINAIRE
STYLE: K424 SINGLE
WIDTH: 5'-11\"/>

LAMP POST SPECIFICATIONS

MANUFACTURER: P&K TUBULAR PRODUCTS INC
STYLE: WASHINGTON ALUMINUM
HEIGHT: 24'-10\"/>

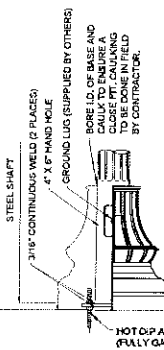
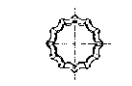
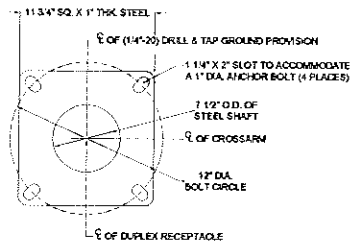
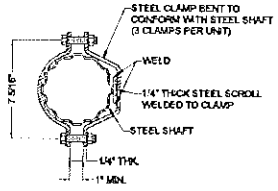
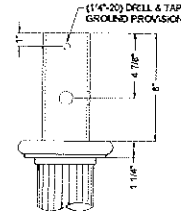
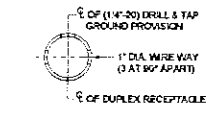

SECTION A-A
6063-T5 ALUMINUM ALLOY
250 WALL THICKNESS
12 FLAT FLUTE
14\"/>



TOWN OF EAST HARTFORD OFFICE OF THE MAYOR

DATE: July 7, 2014
TO: Richard F. Kehoe, Chair
FROM: Mayor Marcia A. Leclerc 
RE: RESOLUTION- Reallocation of Funds

Paul O'Sullivan, Grants Manager, is requesting approval of a Resolution to allow the reallocation of funds through the LoCIP and CIP Programs. There are two completed projects that have a total balance remaining of \$44,602.29. If the Resolution is approved, these funds can be used towards resurfacing the Tennis Courts at East Hartford High School.

Please place this information and Resolution on the July 15, 2014 Town Council agenda.

Thank you.

C: M. Walsh, Finance Director
P. O'Sullivan, Grants Manager
E. Buckheit, Development Director

I, Angela M. Attenello, the duly appointed Clerk of the Town Council of the Town of East Hartford, a corporation organized and existing under the laws of the State of Connecticut, hereby certify that the following is a true copy of a resolution adopted at a meeting of the East Hartford Town Council of said corporation, duly held on the 15th day of July, 2014.

RESOLUTION

WHEREAS the Town of East Hartford currently has a total of \$44,602.29 in Local Capital Improvement Program (LoCIP) funds earmarked to two completed projects; and

WHEREAS the Town desires to reprogram these funds for the repair of the Tennis Courts at East Hartford High School;

NOW THEREFORE LET IT BE RESOLVED; that Marcia A. Leclerc, Mayor of the Town of East Hartford, is authorized to amend the Town Capital Improvement Program (CIP) for the purpose of transferring \$11,730.29 from the Fire House #6 Window and Door Replacement Project (CIP #2013-215) and \$32,872.00 from the Roof Replacement at Drennan and Lord Pools Project (CIP #2014-302) to the Replacement of Tennis Court Surfaces at East Hartford High School Project (CIP #2014-301) and make application to, and execute and approve on behalf of this corporation, any and all documents, contracts, and amendments as may be required by the state Office of Policy and Management as they pertain to these projects and the state Local Capital Improvement Program.

AND I DO CERTIFY that the above resolution has not been in any way altered, amended, or repealed, and is now in full force and effect.

IN WITNESS WHEREOF, I do hereunto set my hand and affix the corporate seal of said Town of East Hartford the ___ day of July, 2014.

Seal

Signed: _____
Angela M. Attenello, Council Clerk

GRANTS ADMINISTRATION
MEMORANDUM

TO: Mayor Marcia A. Leclerc
FROM: Paul O'Sullivan, Grants Manager 
SUBJECT: Council Resolution – CIP and LoCIP Reallocation
DATE: July 3, 2014

Attached is a draft Town Council Resolution amending the Town Capital Improvement Program (CIP) for the purpose of reallocating funds from two completed projects to one that is still in progress.

The Town currently has a total of \$44,602.29 in Local Capital Improvement Program (LoCIP) funds earmarked to two completed projects: \$11,730.29 from the Fire House #6 Window and Door Replacement Project (CIP #2013-215) and \$32,872.00 from the Roof Replacement at Drennan and Lord Pools Project (CIP #2014-302). This resolution will amend the Capital Improvement Program to reallocate these surplus funds to the Replacement of Tennis Court Surfaces at East Hartford High School Project (CIP #2014-301).

I respectfully request that this resolution be placed on the agenda for the Town Council meeting on July 15th, 2014. I will be in attendance at the meeting in case the members of the Council have any questions.

Attachments (3)

Cc: Eileen Buckheit, Development Director

TOWN OF EAST HARTFORD ADOPTED CAPITAL IMPROVEMENT PROGRAM FOR THE FISCAL YEARS 2013-2014 THROUGH 2017-2018

| REF. # | Project Description | Funding Source | Adopted | FY 13-14 | FY 14-15 | FY 15-16 | FY 16-17 | FY 17-18 | TOTAL |
|-----------------------------------|---|----------------|----------------|------------------|------------------|----------------|----------------|----------------|------------------|
| PARKS AND RECREATION | | | | | | | | | |
| 2014-301 | Tennis court - repairs | LOCIP | 75,000 | 240,000 | 240,000 | - | - | 75,000 | 555,000 |
| 2014-302 | Roof Replacement for Drennan and Lord Bathhouses | LOCIP | 75,000 | 75,000 | - | - | - | - | 75,000 |
| 2014-303 | Great River Park lighting and electrical repairs | LOCIP | 25,000 | 50,000 | - | - | - | - | 50,000 |
| 2014-304 | Terry Pool lockers | LOCIP | 20,000 | 20,000 | - | - | - | - | 20,000 |
| 2014-305 | Zero turn mower with bag system | Lease | 17,000 | 17,000 | - | - | 17,000 | - | 34,000 |
| 2014-306 | Drennan Pool - replacement | - | - | 2,000,000 | - | - | - | - | 2,000,000 |
| 2014-307 | Martin Pool - replacement | - | - | 2,000,000 | - | - | - | - | 2,000,000 |
| 2014-308 | Replace Pool Decks at Drennan, filter and return lines | - | - | 274,000 | - | - | - | - | 274,000 |
| 2014-310 | Repair Dam and roadway at Gorman Park Pond | - | - | 150,000 | - | - | - | - | 150,000 |
| 2014-311 | McAuliffe Park - improvements | - | - | 125,000 | 125,000 | 125,000 | - | - | 375,000 |
| 2014-312 | Hockanum River Linear Walkway - Repairs | - | - | 125,000 | - | 25,000 | 65,000 | 65,000 | 280,000 |
| 2014-313 | Dog Park Construction | - | - | 120,000 | - | - | - | - | 120,000 |
| 2014-314 | Portable Stage (Showmobile) Replacement | - | - | 103,500 | - | - | - | - | 103,500 |
| 2014-315 | Repave Parks Maintenance Parking Lot | - | - | 94,000 | - | - | - | - | 94,000 |
| 2014-316 | Large Dump Truck | - | - | 89,000 | - | - | - | - | 89,000 |
| 2014-317 | Skate park equipment - Second Location | - | - | 75,000 | 100,000 | 100,000 | - | - | 275,000 |
| 2014-318 | F550 Dump Truck with Plow | - | - | 72,000 | 78,000 | - | - | - | 150,000 |
| 2014-319 | Small dump truck with plow | - | - | 67,000 | - | - | - | - | 67,000 |
| 2014-320 | EHCCC Phase III - Sealing Bricks below ground sealant | - | - | 50,000 | - | - | - | - | 50,000 |
| 2014-321 | Playscape replacement program | - | - | 40,000 | 40,000 | 40,000 | 40,000 | 40,000 | 200,000 |
| 2014-322 | Martin Park Improvements | - | - | 36,000 | 4,000 | - | 4,000 | - | 44,000 |
| 2014-323 | Hockanum tennis court lights | - | - | 36,000 | - | - | - | - | 36,000 |
| 2014-324 | 3 PT Hitch Tractor | - | - | 35,000 | - | - | - | - | 35,000 |
| 2014-325 | Pick-up truck | - | - | 35,000 | - | - | - | - | 35,000 |
| 2014-326 | VMC Building Repairs | - | - | 30,000 | 15,000 | 8,000 | 8,000 | 8,000 | 69,000 |
| 2014-327 | Community Garden | - | - | 30,000 | - | - | - | - | 30,000 |
| 2014-328 | Repaving/ Crack Sealing Projects | - | - | 25,000 | 25,000 | 25,000 | 25,000 | - | 100,000 |
| 2014-329 | Backstop and Fencing - Replacement Program | - | - | 24,000 | 10,000 | 10,000 | 10,000 | 10,000 | 64,000 |
| 2014-330 | Garbage Collection Systems | - | - | 24,000 | - | - | - | - | 24,000 |
| 2014-331 | Compressor w/ attachments | - | - | 23,000 | - | - | - | - | 23,000 |
| 2014-332 | Exterior Repairs for Brewer House | - | - | 20,000 | - | - | - | - | 20,000 |
| 2014-333 | Replace Sidewalks | - | - | 18,000 | - | - | - | - | 18,000 |
| 2014-334 | Gravelly Tractor with Broom | - | - | 10,100 | - | - | - | - | 10,100 |
| 2014-335 | Surge pit hatch replacement and starting blocks at Terry Pool | - | - | 8,000 | - | - | - | - | 8,000 |
| 2014-336 | EHCCC - Replacement Equipment (chairs, tables, carpet etc.) | - | - | 8,000 | - | - | - | - | 8,000 |
| 2014-337 | Parks Maintenance Office furniture replacement | - | - | 7,500 | - | - | - | - | 7,500 |
| 2014-345 | Brush Hog Mower for 3 Pt hitch Tractor | - | - | 6,500 | - | - | - | - | 6,500 |
| 2014-346 | Replacement pool vacuums | - | - | 6,000 | 6,000 | - | - | - | 12,000 |
| 2014-347 | Automatic External Defibrillators - 2-4 units | - | - | 6,000 | 3,000 | 3,000 | 3,000 | - | 15,000 |
| 2014-348 | Various equipment - scheduled replacement | - | - | - | 150,000 | 175,000 | 175,000 | 200,000 | 700,000 |
| 2014-349 | Yanner Property Development | - | - | - | 125,000 | 75,000 | 35,000 | 35,000 | 270,000 |
| 2014-350 | Labor Park - improvements | - | - | - | 125,000 | 65,000 | 25,000 | - | 215,000 |
| 2014-351 | John Deere 450 Bulldozer 4-way blade | - | - | - | 95,000 | - | - | - | 95,000 |
| 2014-352 | Leaf Vac | - | - | - | - | 16,000 | - | - | 16,000 |
| 2014-353 | Large Rotary Mower | - | - | - | - | 84,000 | - | - | 84,000 |
| PARKS AND RECREATION TOTAL | | | 212,000 | 6,174,600 | 1,141,000 | 751,000 | 407,000 | 433,000 | 8,906,600 |



TOWN OF EAST HARTFORD OFFICE OF THE MAYOR

DATE: July 7, 2014
TO: Richard F. Kehoe, Chair
FROM: Mayor Marcia A. Leclerc 
RE: Tax Liens – Individual Sales

I am forwarding a memo from Michael Walsh, Finance Director, and a list of tax liens that the town is looking to sell. The Town Council approved this list at its meeting held on May 6, 2014. The memo provides an update on addresses removed due to payment by the owner and bids received on the remaining properties.

Please place this information on the July 15, 2014 agenda for approval to allow the town to move forward with this process.

Thank you.

C: M. Walsh, Finance Director



MEMORANDUM

DATE: June 27, 2014

TO: Marcia A. Leclerc, Mayor

FROM: Michael P. Walsh, Director of Finance 

TELEPHONE: (860) 291-7246

RE: Town Council Approval of the Sale of Individual Tax Liens

At the May 6, 2014 Town Council Meeting, the following motion was approved by the Town Council as it relates to tax liens the town is interested in selling.

MOTION By Bill Horan, seconded by Barbara Rossi

To recommend that the Town Council authorize the administration to conduct a tax lien sale by way of a request for proposal (RFP) and to seek and receive sealed bids pursuant to an invitation to bid on a number of tax liens held by the town on specific real property as listed on lists 1 and 2 as produced by Finance Director Mike Walsh and attached to a memorandum dated March 25, 2014 from Mayor Marcia Leclerc to Town Council Chair Richard Kehoe, subject to the following four conditions:

1. The Collector of Revenue shall notify the record owner of each property subject to a lien that is to be included in the tax lien sale, by certified mail, that the lien is being included in the request for proposal and invitation to bid, and that the owner should contact the Town immediately to pay the taxes or seek a payment plan if they wish to keep the Town's tax liens on their property from being sold;
2. In order to qualify for a payment plan, the property owner must meet the following three criteria:
 - a. They must remit 25% of the outstanding amount due
 - b. They cannot have defaulted on a prior payment arrangement
 - c. Their property must not have active property code violations;
3. The letters from the Collector of Revenue to each property owner shall notify the property owner that the purchaser of the tax lien on their property shall have the right to foreclose on that property; and
4. The Administration shall return to the Town Council with the results of the request for proposal and that the proposal for each tax lien must be approved by the Town Council before it is sold.

With respect to the aforementioned motion, having satisfied the conditions of the process articulated by the Town Council, we need to return to the Town Council to seek approval to sell tax liens where the bids received by the Town through the request for proposal (RFP) process were satisfactory.

Know that 105 delinquent accounts totaling \$1,130,112.84 were included on the original list. 58 properties totaling \$511,578.18 were removed from the list when the owners came in and paid in full or entered into a payment plan with the town. Three properties on the list totaling \$4,704.27 did not receive any bids and therefore remain outstanding. Finally, 44 properties totaling \$613,830.39 are being recommended for sale and are presented below for the Town Council's approval:

| | |
|----------------------------|--------------------------------|
| Woods Cove III, LLC | 3 bids totaling \$ 41,295.07 |
| Empire VI CT Portfolio LLC | 40 bids totaling \$ 629,013.22 |
| VMFTL1, LLC | 1 bid totaling \$ 5,962.81 |

It should be noted that all bids were at or above the tax and interest due to the town and resulted in an excess payment of \$62,440.71

Once these liens are sold, the property owner will have the opportunity to redeem these liens from the new owner based on a time period established by Connecticut General Statutes.

Based on these recommendations, I would respectfully request that this package of information be forwarded along to the Town Council for their approval.

Should you have any questions or problems on the aforementioned, please feel free to let me know.

Cc: Attorney Richard Gentile, Assistant Corporation Counsel
Iris Laurenza, Tax Collector

| BILL# | UNIQUE ID | NAME | PROPERTY LOCATION | Del. 8/31/14 | Woods Cove III | Empire IV | VMFTLI, LLC |
|-----------------|-----------|----------------------------|-----------------------|--------------|----------------|-----------|-------------|
| 2011-01-0000039 | 1628 | 185 BURNHAM STREET LLC | 185 BURNHAM ST | | | | |
| 2012-01-0000039 | 1628 | 185 BURNHAM STREET LLC | 185 BURNHAM ST | | | | |
| TOTAL | 2 | | 1628 185 BURNHAM ST | | 38,043.31 | | 42,038.00 |
| 2012-01-0003003 | 11035 | CONNECTICUT FREEZERS INC | 241 PARK AVE | | | | |
| TOTAL | 1 | | 11035 241 PARK AVE | | 31,766.31 | | 35,102.00 |
| 2011-01-0011620 | 8755 | 1111 MAIN ST L L C | 1111 MAIN ST | | | | |
| 2012-01-0011620 | 8755 | 1111 MAIN ST L L C | 1111 MAIN ST | | | | |
| TOTAL | 2 | | 8755 1111 MAIN ST | | 20,707.90 | | 22,904.00 |
| 2010-01-0014647 | 13224 | PROPERTY LIQUIDATION L L C | 71-73 SISSON ST | | | | |
| 2011-01-0014647 | 13224 | PROPERTY LIQUIDATION L L C | 71-73 SISSON ST | | | | |
| 2012-01-0014647 | 13224 | PROPERTY LIQUIDATION L L C | 71-73 SISSON ST | | | | |
| TOTAL | 3 | | 13224 71-73 SISSON ST | | 20,383.98 | | 22,525.00 |
| 2010-01-0006876 | 6414 | GOOD GUYZ L L C | 11 HIGHLAND ST | | | | |
| 2011-01-0006876 | 6414 | GOOD GUYZ L L C | 11 HIGHLAND ST | | | | |
| 2012-01-0006876 | 6414 | GOOD GUYZ L L C | 11 HIGHLAND ST | | | | |
| TOTAL | 3 | | 6414 11 HIGHLAND ST | | 19,834.84 | | 21,918.00 |
| 2010-01-0002794 | 10538 | COATES BARBARA E EST OF | 508 OAK ST | | | | |
| 2011-01-0002794 | 10538 | COATES BARBARA E EST OF | 508 OAK ST | | | | |
| 2012-01-0002794 | 10538 | COATES BARBARA E EST OF | 508 OAK ST | | | | |
| TOTAL | 3 | | 10538 508 OAK ST | | 18,916.51 | | 20,904.00 |
| 2010-01-0010764 | 3372 | OGLE CLELLA EST OF | 100 CORNELL CIR | | | | |
| 2011-01-0010764 | 3372 | OGLE JAMES J 1/2 INT | 100 CORNELL CIR | | | | |
| 2012-01-0010764 | 3372 | OGLE JAMES J 1/2 INT | 100 CORNELL CIR | | | | |
| TOTAL | 3 | | 3372 100 CORNELL CIR | | 18,018.51 | | 20,023.00 |
| 2010-01-0011855 | 2988 | PSARAS ELIAS J | 70-72 CLOVERDALE DR | | | | |
| 2011-01-0011855 | 2988 | PSARAS ELIAS J EST OF | 70-72 CLOVERDALE DR | | | | |
| 2012-01-0011855 | 2988 | PSARAS ELIAS J EST OF | 70-72 CLOVERDALE DR | | | | |

| BILL# | UNIQUE ID | NAME | PROPERTY LOCATION | Del. 8/31/14 | Woods Cove III | Empire IV | VMFTLI, LLC |
|-----------------|-----------|---------------------------|-----------------------------|--------------|----------------|-----------|-------------|
| TOTAL | 3 | | 2988 70-72 CLOVERDALE DR | 18,434.39 | | 20,371.00 | |
| 2010-01-0011169 | 8913 | PASSARO ARDEN N JR | 1879 MAIN ST | | | | |
| 2011-01-0011169 | 8913 | PASSARO ARDEN N JR | 1879 MAIN ST | | | | |
| 2012-01-0011169 | 8913 | PASSARO ARDEN N JR | 1879 MAIN ST | | | | |
| TOTAL | 3 | | 8913 1879 MAIN ST | 17,815.82 | | 19,687.00 | |
| 2011-01-0003082 | 108 | CORBETT PENNY A | 10-12 AMY DR | | | | |
| 2012-01-0003082 | 108 | CORBETT PENNY A | 10-12 AMY DR | | | | |
| TOTAL | 2 | | 108 10-12 AMY DR | 16,407.85 | | 18,131.00 | |
| 2010-01-0000780 | 1404 | SOUZA BAILEY VIRGINIA M | 85 BROOKFIELD DR | | | | |
| 2011-01-0000780 | 1404 | SOUZA BAILEY VIRGINIA M | 85 BROOKFIELD DR | | | | |
| 2012-01-0000780 | 1404 | SOUZA BAILEY VIRGINIA M | 85 BROOKFIELD DR | | | | |
| TOTAL | 3 | | 1404 85 BROOKFIELD DR | 16,360.54 | | 18,080.00 | |
| 2011-01-0015511 | 15781 | WILLOCKS DAN A | 235 EAST RIVER DR 303 | | | | |
| 2012-01-0015511 | 15781 | WILLOCKS DAN A | 235 EAST RIVER DR 303 | | | | |
| TOTAL | 2 | | 15781 235 EAST RIVER DR 303 | 16,153.50 | | 17,851.00 | |
| 2010-01-0009742 | 2551 | ORTEGA ELISA | 30 CHESTER ST | | | | |
| 2011-01-0009742 | 2551 | ORTEGA ELISA | 30 CHESTER ST | | | | |
| 2012-01-0009742 | 2551 | ORTEGA ELISA | 30 CHESTER ST | | | | |
| TOTAL | 3 | | 2551 30 CHESTER ST | 15,974.69 | | 17,653.00 | |
| 2010-01-0005278 | 3076 | FRALEIGH CARL F & NANCY N | 27 COLLIMORE RD | | | | |
| 2011-01-0005278 | 3076 | FRALEIGH CARL F & NANCY N | 27 COLLIMORE RD | | | | |
| 2012-01-0005278 | 3076 | FRALEIGH CARL F & NANCY N | 27 COLLIMORE RD | | | | |
| TOTAL | 3 | | 3076 27 COLLIMORE RD | 15,981.94 | | 17,660.00 | |
| 2010-01-0007239 | 848 | JOBES EDWARD & PATRICIA C | 98-100 BLISS ST | | | | |
| 2011-01-0007239 | 848 | JOBES EDWARD & PATRICIA C | 98-100 BLISS ST | | | | |
| 2012-01-0007239 | 848 | JOBES EDWARD & PATRICIA C | 98-100 BLISS ST | | | | |
| TOTAL | 3 | | 848 98-100 BLISS ST | 15,629.15 | | 17,275.00 | |

| BILL# | UNIQUE ID | NAME | PROPERTY LOCATION | Del. 8/31/14 | Woods Cove III | Empire IV | VMFTLI, LLC |
|-----------------|-----------|----------------------------|------------------------------|--------------|----------------|-----------|-------------|
| 2012-01-0002405 | 15872 | CARUSONE JOHN | 235 EAST RIVER DR 1701 | | | | |
| TOTAL | 1 | | 15872 235 EAST RIVER DR 1701 | 15,281.41 | | 16,887.00 | |
| 2010-01-0014517 | 1023 | TOMASO HELEN J | 110 BRENTMOOR RD | | | | |
| 2011-01-0014517 | 1023 | TOMASO HELEN J | 110 BRENTMOOR RD | | | | |
| 2012-01-0014517 | 1023 | TOMASO HELEN J | 110 BRENTMOOR RD | | | | |
| TOTAL | 3 | | 1023 110 BRENTMOOR RD | 13,641.40 | | 15,075.00 | |
| 2010-01-0010037 | 405 | MONTANEZ RAUL P & AWILDA N | 113 ARNOLD DR | | | | |
| 2011-01-0010037 | 405 | MONTANEZ RAUL P & AWILDA N | 113 ARNOLD DR | | | | |
| 2012-01-0010037 | 405 | MONTANEZ RAUL P & AWILDA N | 113 ARNOLD DR | | | | |
| TOTAL | 3 | | 405 113 ARNOLD DR | 13,599.13 | | 15,030.00 | |
| 2011-01-0014492 | 1703 | 66 BURNSIDE AVENUE L L C | 66 BURNSIDE AVE | | | | |
| 2012-01-0014492 | 1703 | 66 BURNSIDE AVENUE L L C | 66 BURNSIDE AVE | | | | |
| TOTAL | 2 | | 1703 66 BURNSIDE AVE | 13,595.45 | | 15,025.00 | |
| 2010-01-0015823 | 14019 | ZOCCO CHESTER C JR | 135 TOLLAND ST | | | | |
| 2011-01-0015823 | 14019 | ZOCCO CHESTER C JR | 135 TOLLAND ST | | | | |
| 2012-01-0015823 | 14019 | ZOCCO CHESTER C JR | 135 TOLLAND ST | | | | |
| TOTAL | 3 | | 14019 135 TOLLAND ST | 13,370.93 | | 14,707.00 | |
| 2012-01-0009863 | 2012 | MILIOS DESPINA | 1111 BURNSIDE AVE | | | | |
| TOTAL | 1 | | 2012 1111 BURNSIDE AVE | 13,437.72 | | 14,865.00 | |
| 2010-01-0001855 | 495 | BRUNO NICHOLAS & ALICE L/U | 10 BARBARA DR | | | | |
| 2011-01-0001855 | 495 | BRUNO NICHOLAS & ALICE L/U | 10 BARBARA DR | | | | |
| 2012-01-0001855 | 495 | BRUNO NICHOLAS & ALICE L/U | 10 BARBARA DR | | | | |
| TOTAL | 3 | | 495 10 BARBARA DR | 13,116.39 | | 14,428.00 | |
| 2011-01-0006292 | 4095 | TORRES JULIO | 52 ELLSWORTH ST | | | | |
| 2012-01-0006292 | 4095 | TORRES JULIO | 52 ELLSWORTH ST | | | | |
| TOTAL | 2 | | 4095 52 ELLSWORTH ST | 12,476.33 | | 13,825.00 | |
| 2012-01-0004617 | 14023 | 145-149 TOLLAND L L C | 145-149 TOLLAND ST | | | | |

| BILL# | UNIQUE ID | NAME | PROPERTY LOCATION | Del. 8/31/14 | Woods Cove III | Empire IV | VMFTLI, LLC |
|-----------------|-----------|----------------------------|--------------------------|--------------|----------------|-----------|-------------|
| TOTAL | 1 | | 14023 145-149 TOLLAND ST | 12,514.25 | | 13,830.00 | |
| 2012-01-0012657 | 2002 | AMIRZAI PROPERTY TRUST LLC | 1071 BURNSIDE AVE | | | | |
| TOTAL | 1 | | 2002 1071 BURNSIDE AVE | 12,293.34 | | 13,615.00 | |
| 2010-01-0000737 | 6806 | BACON BUFFEY | 103 HOCKANUM DR | | | | |
| 2011-01-0000737 | 6806 | BACON BUFFEY | 103 HOCKANUM DR | | | | |
| 2012-01-0000737 | 6806 | BACON BUFFEY | 103 HOCKANUM DR | | | | |
| TOTAL | 3 | | 6806 103 HOCKANUM DR | 12,140.54 | | 13,420.00 | |
| 2010-01-0008952 | 7932 | MAGYAR IMRE | 16 LAUREL ST | | | | |
| 2011-01-0008952 | 7932 | MAGYAR IMRE | 16 LAUREL ST | | | | |
| 2012-01-0008952 | 7932 | MAGYAR IMRE | 16 LAUREL ST | | | | |
| TOTAL | 3 | | 7932 16 LAUREL ST | 12,083.93 | 12,869.39 | | |
| 2011-01-0013497 | 16567 | SIMONI ROBERT J | 944 TOLLAND ST 1 | | | | |
| 2012-01-0013497 | 16567 | SIMONI ROBERT J | 944 TOLLAND ST 1 | | | | |
| TOTAL | 2 | | 16567 944 TOLLAND ST 1 | 11,732.86 | | 12,972.00 | |
| 2011-01-0014669 | 4209 | TUCKER CALVIN A & WANDA D | 22 EVANS AVE | | | | |
| 2012-01-0014669 | 4209 | TUCKER CALVIN A & WANDA D | 22 EVANS AVE | | | | |
| TOTAL | 2 | | 4209 22 EVANS AVE | 11,665.44 | | 12,955.00 | |
| 2010-01-0003067 | 7113 | COOPER JOAN M | 80 JAMES ST | | | | |
| 2011-01-0003067 | 7113 | COOPER JOAN M | 80 JAMES ST | | | | |
| 2012-01-0003067 | 7113 | COOPER JOAN M | 80 JAMES ST | | | | |
| TOTAL | 3 | | 7113 80 JAMES ST | 11,350.26 | 12,088.03 | | |
| 2010-01-0013600 | 7175 | 24 JEFFREY DRIVE L L C | 24 JEFFREY DR | | | | |
| 2011-01-0013600 | 7175 | 24 JEFFREY DRIVE L L C | 24 JEFFREY DR | | | | |
| 2012-01-0013600 | 7175 | 24 JEFFREY DRIVE L L C | 24 JEFFREY DR | | | | |
| TOTAL | 3 | | 7175 24 JEFFREY DR | 11,053.30 | | 12,216.00 | |
| 2011-01-0014829 | 1827 | VALENTI JOSEPH D | 433 BURNSIDE AVE | | | | |
| 2012-01-0014829 | 1827 | VALENTI JOSEPH D | 433 BURNSIDE AVE | | | | |

| BILL# | UNIQUE ID | NAME | PROPERTY LOCATION | Del. 8/31/14 | Woods Cove III | Empire IV | VMFTLI, LLC |
|--|-----------|----------------------------------|----------------------------|--------------|----------------|-----------|-------------|
| TOTAL | 2 | | 1827 433 BURNSIDE AVE | 10,878.48 | | 12,025.00 | |
| 2009-01-0002927 | 15483 | CONDO 64 L L C | 505 BURNSIDE AVE UNIT A-7 | | | | |
| 2010-01-0002927 | 15483 | CONDO 64 L L C | 505 BURNSIDE AVE UNIT A-7 | | | | |
| 2011-01-0002927 | 15483 | CONDO 64 L L C | 505 BURNSIDE AVE A-7 | | | | |
| 2012-01-0002927 | 15483 | CONDO 64 L L C | 505 BURNSIDE AVE A-7 | | | | |
| TOTAL | 4 | | 15483 505 BURNSIDE AVE A-7 | 5,962.81 | | | 5,962.81 |
| 2010-01-0010774 | 14045 | CRUZ MARISOL V | 255-257 TOLLAND ST | | | | |
| 2011-01-0010774 | 14045 | CRUZ MARISOL V | 255-257 TOLLAND ST | | | | |
| 2012-01-0010774 | 14045 | CRUZ MARISOL V | 255-257 TOLLAND ST | | | | |
| TOTAL | 3 | CRUZ MARISOL V | 255-257 TOLLAND ST | 12,886.15 | | 14,240.00 | |
| 2012-01-0013975 | 828 | CRUZ MARISOL V | 61 BLISS ST | | | | |
| TOTAL | 1 | CRUZ MARISOL V | 61 BLISS ST | 2,747.66 | | 3,035.00 | |
| 2012-01-0000022 | 13125 | GARDEN CENTER PROPERTY L L C | 1375 SILVER LN | | | | |
| TOTAL | 1 | GARDEN CENTER PROPERTY L L C | 1375 SILVER LN | 13,082.11 | | 14,458.00 | |
| 2012-01-0000020 | 3336 | GARDEN CENTER PROPERTY L L C | 35 COPPER BEECH WAY | | | | |
| TOTAL | 1 | GARDEN CENTER PROPERTY L L C | 35 COPPER BEECH WAY | 807.00 | | 893.00 | |
| 2010-01-0007559 | 8491 | KEARNS KEVIN | 38 MAIN ST REAR | | | | |
| 2011-01-0007559 | 8491 | KEARNS KEVIN | 38 MAIN ST | | | | |
| 2012-01-0007559 | 8491 | KEARNS KEVIN | 38 MAIN ST | | | | |
| TOTAL | 3 | KEARNS KEVIN | 38 MAIN ST | 5,135.42 | | 5,469.22 | |
| Payment Arrangements in Default | | | | | | | |
| 2010-01-0011099 | 2480 | RESIDENTIAL REHABILITATION L L C | 14-16 CHERRY ST | | | | |
| 2011-01-0011099 | 2480 | RESIDENTIAL REHABILITATION L L C | 14-16 CHERRY ST | | | | |
| 2012-01-0011099 | 2480 | RESIDENTIAL REHABILITATION L L C | 14-16 CHERRY ST | | | | |
| TOTAL | 3 | | 2480 14-16 CHERRY ST | 13,244.14 | | 14,635.00 | |
| 2011-01-0000243 | 14399 | ADONIS JEANINE & MARYSE | 29 WADSWORTH ST | | | | |

| BILL# | UNIQUE ID | NAME | PROPERTY LOCATION | Del. 8/31/14 | Woods Cove III | Empire IV | VMFTLI, LLC |
|--------------------------|-----------|-------------------------|-----------------------|---------------------|------------------|-------------------|-----------------|
| 2012-01-0000243 | 14399 | ADONIS JEANINE & MARYSE | 29 WADSWORTH ST | | | | |
| TOTAL | 3 | | 14399 29 WADSWORTH ST | 9,413.91 | | 10,401.00 | |
| 2011-01-0010328 | 4885 | BALESANO DOROTHY & DEAN | 450 FOREST ST | | | | |
| 2012-01-0010328 | 4885 | BALESANO DOROTHY & DEAN | 450 FOREST ST | | | | |
| TOTAL | 2 | | 4885 450 FOREST ST | 8,365.78 | | 9,245.00 | |
| 2010-01-0007130 | 9424 | JACQUES WAYNE B | 16 MAY ST | | | | |
| 2011-01-0007130 | 9424 | JACQUES WAYNE B | 16 MAY ST | | | | |
| 2012-01-0007130 | 9424 | JACQUES WAYNE B | 16 MAY ST | | | | |
| TOTAL | 3 | | 9424 16 MAY ST | 6,401.11 | | 7,075.00 | |
| 2010-01-0007860 | 7989 | KOSCINSKI MARTHA B | 73 LAWRENCE ST | | | | |
| 2011-01-0007860 | 7989 | KOSCINSKI MARTHA B | 73 LAWRENCE ST | | | | |
| 2012-01-0007860 | 7989 | KOSCINSKI MARTHA B | 73 LAWRENCE ST | | | | |
| TOTAL | 3 | KOSCINSKI MARTHA B | 73 LAWRENCE ST | 5,783.38 | | 6,565.00 | |
| 2010-01-0009503 | 3507 | MCCRAY CAROLYN E | 113 CRESCENT DR | | | | |
| 2011-01-0009503 | 3507 | MCCRAY CAROLYN E | 113 CRESCENT DR | | | | |
| 2012-01-0009503 | 3507 | MCCRAY CAROLYN E | 113 CRESCENT DR | | | | |
| TOTAL | 3 | | 3507 113 CRESCENT DR | 15,340.52 | 16,337.65 | | |
| Total Delinquent: | | | | \$613,830.39 | 41,295.07 | 629,013.22 | 5,962.81 |



TOWN OF EAST HARTFORD OFFICE OF THE MAYOR

DATE: July 7, 2014
TO: Richard F. Kehoe, Chair
FROM: Mayor Marcia A. Leclerc 
RE: REFUND OF TAXES

I recommend that the Town Council approve a total refund of taxes in the amount of \$86,997.22 as detailed in the attached listing from our Collector of Revenue.

Please place on the Town Council agenda for the July 15, 2014 Town Council meeting.

Thank you.

C: I. Laurenza, Tax Collector
M. Walsh, Finance Director

INTEROFFICE MEMORANDUM

TO: MARCIA A LECLERC, MAYOR ✓
MICHAEL WALSH, DIRECTOR OF FINANCE

FROM: IRIS LAURENZA, COLLECTOR OF REVENUE 

SUBJECT: REFUND OF TAXES

DATE: 7/3/2014

Under the provisions of Section 12-129 of the Connecticut General Statutes, the following persons are entitled to the refunds as requested. The total amount to be refunded is \$86,997.22 Please see attached listing.

| Bill | Name | Address | Prop Loc/Vehicle Info. | Over Paid |
|----------------------|-----------------------------|--|------------------------|-------------------|
| 2011-01-0002910 | COMMERCE CENTER ASSOCIATION | 342 NORTH MAIN ST SUITE 200 | 341 EAST RIVER DR | -38,330.44 |
| 2012-01-0002910 | COMMERCE CENTER ASSOCIATION | WEST HARTFORD CT 06117 | 341 EAST RIVER DR | -39,324.74 |
| 2012-01-0002328 | TEN BEACH STREET LLC | 235 EAST RIVER DR #1601 EAST HARTFORD CT 06108 | 31 HIGH ST 10208 | -3,153.62 |
| 2012-01-0015777 | ZELIGZON RAFAEL | 430 BURNSIDE AVE EAST HARTFORD CT 06108 | 430 BURNSIDE AVE | -1,815.15 |
| 2012-03-0054984 | CAB EAST LLC | BOX 105704 ATLANTA GA 30348 | 2011/3FAHP0HA1BR283576 | -262.74 |
| 2012-03-0054988 | CAB EAST LLC | | 2010/2FMDK4JC6ABB61234 | -181.74 |
| 2012-03-0054992 | CAB EAST LLC | | 2011/1FMHK8D87BGA52775 | -657.36 |
| 2012-03-0058509 | DAIMLER TRUST | BOX 685 ROANOKE TX 76262-0685 | 2009/WDDGF81X99R081764 | -724.22 |
| 2012-03-0075407 | NISSAN INFINITI LT | 915 L STREET PMBC436 SACRAMENTO CA 95814 | 2010/1N4AL2AP9AN482898 | -245.40 |
| 2012-03-0077737 | PETERSON D L TRUST | 940 RIDGEBROOK ROAD SPARKS MD | 2009/1GBHG31C891180798 | -435.84 |
| 2012-03-0081515 | RYDER TRUCK RENTAL INC | 99 MURPHY RD HARTFORD CT 06114-2104 | 2006/4V4NC9TG46N414778 | -268.1 |
| 2012-03-0081516 | RYDER TRUCK RENTAL INC | | 2006/4V4NC9TG66N414779 | -268.1 |
| 2012-03-0081533 | RYDER TRUCK RENTAL INC | | 2009/JALC4W16397001637 | -593.53 |
| 2012-03-0081543 | RYDER TRUCK RENTAL INC | | 2011/1HTMKAAL9BH368582 | -390.22 |
| 2012-03-0087035 | VESKO JASON J | 3694 TREASURE COVE CIR NAPLES FL 34114 | 2012/1C4AJWAG6CL186064 | -258.62 |
| 2012-04-0082421 | EAN HOLDINGS LLC | 6929 N LAKEWOOD AVE TULSA OK 74117 | 2013/1C3CDZAB8DN593920 | -87.4 |
| TOTAL REFUNDS | | | | -86,997.22 |

RESOLUTION APPROPRIATING \$15,000,000 FOR THE PLANNING, DESIGN, CONSTRUCTION AND RECONSTRUCTION OF TOWN ROADS AND PARKING LOTS AND AUTHORIZING THE ISSUANCE OF \$15,000,000 BONDS OF THE TOWN TO MEET SAID APPROPRIATION AND PENDING THE ISSUANCE THEREOF THE MAKING OF TEMPORARY BORROWINGS FOR SUCH PURPOSE

BE IT RESOLVED BY THE TOWN COUNCIL OF THE TOWN OF EAST HARTFORD:

Section 1. The sum of \$15,000,000 is appropriated by the Town of East Hartford, Connecticut (the "Town") for the planning, design, construction and reconstruction of Town roads and parking lots, including rebuilding, resurfacing, drainage, conduits, and related subsurface and infrastructure improvements, and for administrative, legal and financing costs related thereto (the "Project").

Section 2. To meet said appropriation, \$15,000,000 bonds of the Town or so much thereof as shall be necessary for such purpose, shall be issued, maturing not later than the tenth year after their date. Said bonds may be issued in one or more series as determined by the Mayor, the Treasurer and the Director of Finance in the amount necessary to meet the Town's share of the cost of the Project, provided that the total amount of bonds to be issued shall not be less than an amount which will provide funds sufficient with other funds available for such purpose to pay the principal of and the interest on all temporary borrowings in anticipation of the receipt of the proceeds of said bonds outstanding at the time of the issuance thereof, and to pay for the administrative, printing and legal costs of issuing the bonds. The bonds shall be in the denominations of \$1,000, or any whole multiple in excess thereof, be issued fully registered form, be executed in the name and on behalf of the Town by the facsimile or manual signatures of the Mayor and the Treasurer, bear the Town seal or a facsimile thereof, be certified by a bank or trust company which bank or trust company may be designated the registrar and transfer agent, be payable at a bank or trust company and be approved as to their legality by Robinson & Cole LLP, Attorneys-at-Law, of Hartford, Connecticut. The bonds shall be general obligations of the Town and each of the bonds shall recite that every requirement of law relating to its issue has been duly complied with, that such bond is within every debt and other limit prescribed by law, and that the full faith and credit of the Town are pledged to the payment of the principal thereof and interest thereon. The aggregate principal amount of the bonds of each series to be issued, the annual installments of principal, redemption provisions, if any, the certifying, registrar and transfer agent and paying agent, the date, time of issue and sale and other terms, details and particulars of such bonds, including approval of the rate or rates of interest, shall be determined by the Mayor, the Treasurer and the Director of Finance in accordance with the General Statutes of Connecticut, Revision of 1958, as amended from time to time (the "Connecticut General Statutes").

Section 3. Said bonds shall be sold by the Mayor, the Treasurer and the Director of Finance in a competitive offering or by negotiation, in their discretion. If sold in a competitive offering, the bonds shall be sold at not less than par and accrued interest on the basis of the lowest net or true interest cost to the Town. A notice of sale or a summary thereof describing the bonds and setting forth the terms and conditions of the sale shall be published at least five days in advance of the sale in a recognized publication carrying municipal bond notices and devoted primarily to financial news and the subject of state and municipal bonds. If the bonds are sold by negotiation, provisions of the purchase agreement shall be approved by the Mayor, the Treasurer and the Director of Finance.

Section 4. The Mayor, the Treasurer and the Director of Finance are authorized to make temporary borrowings in anticipation of the receipt of the proceeds of said bonds. Notes evidencing such borrowings shall be signed by the Mayor and the Treasurer, have the seal of the Town affixed, be payable at a bank or trust company designated by the Mayor, the Treasurer and the Director of Finance, be approved as to their legality by Robinson & Cole LLP, Attorneys-at-Law, of Hartford, Connecticut, and be certified by a bank or trust company designated by the Mayor, the Treasurer and the Director of Finance pursuant to Section 7-373 of the Connecticut General Statutes. They shall be issued with maturity dates which comply with the provisions of the Connecticut General Statutes governing the issuance of such notes. The notes shall be general obligations of the Town and

each of the notes shall recite that every requirement of law relating to its issue has been duly complied with, that such note is within every debt and other limit prescribed by law, and that the full faith and credit of the Town are pledged to the payment of the principal thereof and the interest thereon. The net interest cost on such notes, including renewals thereof, and the expense of preparing, issuing and marketing them, to the extent paid from the proceeds of such renewals or said bonds, shall be included as a cost of the Project. Upon the sale of the bonds, the proceeds thereof, to the extent required, shall be applied forthwith to the payment of the principal of and the interest on any such notes then outstanding or shall be deposited with a bank or trust company in trust for such purpose.

Section 5. The Town hereby expresses its official intent pursuant to Section 1.150-2 of the Federal Income Tax Regulations, Title 26 (the "Regulations"), to reimburse expenditures paid sixty days prior to and anytime after the date of passage of this resolution in the maximum amount of the Project with the proceeds of bonds, notes or other obligations ("Tax Exempt Obligations") authorized to be issued by the Town. The Tax Exempt Obligations shall be issued to reimburse such expenditures not later than 18 months after the later of the date of the expenditure or the substantial completion of the Project, or such later date the Regulations may authorize. The Town hereby certifies that the intention to reimburse as expressed herein is based upon its reasonable expectations as of this date. The Director of Finance or his designee is authorized to pay Project expenses in accordance herewith pending the issuance of the Tax Exempt Obligations.

Section 6. The Mayor, the Treasurer and the Director of Finance are hereby authorized, on behalf of the Town, to enter into agreements or otherwise covenant for the benefit of bondholders to provide information on an annual or other periodic basis to Municipal Securities Rulemaking Board (the "MSRB") and to provide notices to the MSRB of certain events as enumerated in Securities and Exchange Commission Exchange Act Rule 15c2-12, as amended, as may be necessary, appropriate or desirable to effect the sale of the bonds and notes authorized by this resolution. Any agreements or representations to provide information to MSRB made prior hereto are hereby confirmed, ratified and approved.

Section 7. The Mayor, the Treasurer and the Director of Finance are hereby authorized, on behalf of the Town, to enter into any other agreements, instruments, documents and certificates, including tax and investment agreements, for the consummation of the transactions contemplated by this resolution. The Mayor, the Treasurer and the Director of Finance are hereby authorized, on behalf of the Town, to apply for and accept any and all Federal and State loans and or grants-in-aid of any Project, to expend said funds in accordance with the terms hereof, and in connection therewith to contract in the name of the Town with engineers, contractors and others.

I HEREBY APPROVE the above action taken by the Town Council on _____, 2014 appropriating \$15,000,000 for the Project, authorizing general obligation bonds and notes to finance the Project and submitting same to the electors for approval or disapproval.

Dated at East Hartford, Connecticut this ____ day of _____, 2014.

MARCIA A. LECLERC, Mayor

Witness

Witness



TOWN OF EAST HARTFORD OFFICE OF THE MAYOR

Date: July 7, 2014
TO: Richard F. Kehoe, Chair
FROM: Mayor Marcia A. Leclerc 
RE: APPOINTMENTS - Boards and Commissions

The following names were submitted to me for appointment to the Patriotic Commission:

| | | | |
|---|------------------|--------------------------|-------------|
| D | Robert Falkevitz | 6 Burke Street 06118 | Term: 12/15 |
| R | Timothy Siggia | 145 Arbutus Street 06108 | Term: 12/16 |

Please place these names on the Town Council agenda for the July 15, 2014 meeting.

Thank you.

**TOWN OF EAST HARTFORD, CT
STATEMENT OF INTEREST IN SERVING ON A
BOARD OR COMMISSION**

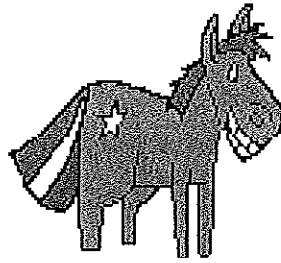

The Town of East Hartford, CT is a "Minority Representation" Municipal Government.

This Form is to be used to request nomination to a position by the East Hartford Democratic Town Committee and will be submitted to its Permanent Nominating Committee for consideration.

Democratic Town Committee Chairman, Donald M. Currey

-Please print and complete the following information in full-

1. Robert J Falkovitz 2. 6 Burke St. 06118
Your name exactly as it appears on the E. Htfd. Voter Registration List Street Address Zip Code

3. PARTY AFFILIATION DEMOCRAT UNAFFILIATED MINOR PARTY

4. (860) 568-5452 5. (860) 558-1502 6. rfalkovitz@att.net
Home Phone Cell Phone Personal e-mail address

7. Retired 8. _____
Occupation Employer

9. _____ 10. _____
Employer/Work Address Work Phone

11. B.S. 12. _____ 13. 40
Formal Education Level Achieved Ethnicity (Optional) Years as E. Htfd. Resident

14. Patriotic
Name of Board or Commission you would like to serve on

15. Dem. Dist 6 Member, Boy Scouts (retired), Knights of Columbus Fourth Degree
*Community based activities and/or civic/volunteer organizations activities you have participated in

16. The K of C Fourth Degree is the Patriotic arm and I am an officer
*Your reason for being interested in serving our Town in this capacity

17. Have participated in patriotic organizations throughout state.
*List any qualifications you believe will be an asset to the board or commission on which you wish to serve

*Please use the back of this page if you need more space or attach a resume if you wish

18. Robert J. Falkovitz 19. 4/24/14
YOUR SIGNATURE DATE

THIS SPACE FOR USE BY DEMOCRATIC TOWN COMMITTEE

Submitted for consideration by Town Committee Member Thomas Frost

Voter Registration Information Certified by Voter Registrar Judith Sheehan

At a duly called meeting of the E. Htfd. Democratic Town Committee's Permanent Nominating Committee and by majority vote, the East Hartford Resident described above is hereby nominated for appointment to the: Patriotic Commission

C. Condio 6.19.14
Catherine F. Condio Secretary Date
(Revised 3.28.12)

**TOWN OF EAST HARTFORD, CT
STATEMENT OF INTEREST IN SERVING ON A
BOARD OR COMMISSION**

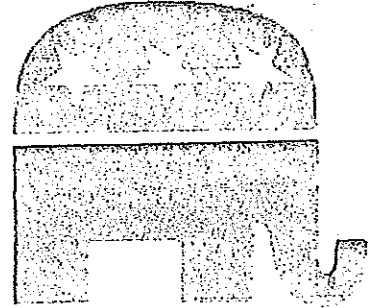

The Town of East Hartford, CT is a "Minority Representation" Municipal Government.

This Form is to be used to request nomination to a position by the East Hartford Republican Town Committee and will be submitted to its Permanent Nominating Committee for consideration.

Republican Town Committee Chairman,

-Please print and complete the following information in full-

1. TIMOTHY M. SIGGIA
Your name exactly as it appears on the E. Htfd. Voter Registration List

2. 145 ARIZUTUS ST. 06108
Street Address Zip Code

3. PARTY AFFILIATION REPUBLICAN UNAFFILIATED OTHER _____

4. 810-289-1679
Home Phone

5. _____
Cell Phone

6. TSiggia145@comcast.net
Personal e-mail address

7. RETIRED
Occupation

8. N/A
Employer

9. N/A
Employer/Work Address

10. N/A
Work Phone

11. B.A.
Formal Education Level Achieved

12. WHITE
Ethnicity (Optional)

13. 68
Years as E. Htfd. Resident

14. PATRIOTIC COMMISSION
Name of Board or Commission you would like to serve on

15. VETERANS AFFAIRS COMMISSION, ZBA, VIETNAM VETERANS OF AMERICA (H-120)
*Community based activities and/or civic/volunteer organizations activities you have participated in

16. FUNCTIONS RELATED TO VETERANS AFFAIRS COMM.
*Your reason for being interested in serving our Town in this capacity

17. RETIRED CHIEF PETTY OFFICER, USN
*List any qualifications you believe will be an asset to the board or commission on which you wish to serve

*Please use the back of this page if you need more space or attach a resume if you wish

18. Timothy M. Siggia
YOUR SIGNATURE

06/09/2014
DATE

THIS SPACE FOR USE BY REPUBLICAN TOWN COMMITTEE

Submitted for consideration by Town Committee Member _____
Voter Registration Information Certified by Voter Registrar _____

At a duly called meeting of the E. Htfd. Republican Town Committee's Permanent Nominating Committee and by majority vote, the East Hartford Resident described above is hereby nominated for appointment to the:

Republican Town Committee Secretary

6/9/14
Date

EAST HARTFORD REPUBLICAN TOWN COMMITTEE

505 Burnside Ave (C14), East Hartford CT 06108

860/983-4104

email: jackwjacobs@sbcglobal.net

HON MARCIA LECLERC
MAYOR OF EAST HARTFORD
740 MAIN ST
EAST HARTFORD CT 06108

June 10, 2014

Dear Mayor Leclerc:

The EHRTC recommends Timothy M. Siggia of 145 Arbutus Street (860 289-1679; tsiggia145@comcast.net) to fill the seat on the Patriotic Commission vacated by Charles Clarke.

Sincerely yours,

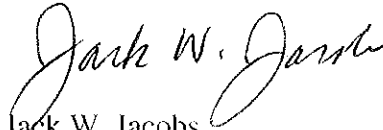

Jack W. Jacobs
Chair, EHRTC

cc: Robert J. Pasek, Town Clerk
Margaret A. Byrnes, Chair

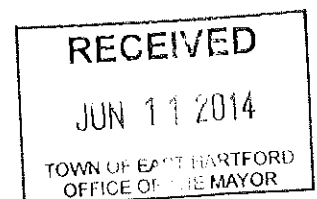



TOWN OF EAST HARTFORD OFFICE OF THE MAYOR

DATE: July 7, 2014
TO: Richard F. Kehoe, Chair
FROM: Mayor Marcia A. Leclerc 
RE: REFERRAL- Real Estate Acquisition and Disposition Committee

Attached is a letter from Kevin Kearns, part owner of 1855 and 1859 Main Street, offering to turn these parcels of property over to the town and be relieved of the delinquent taxes.

Please place on the Town Council agenda for referral to the Real Estate Acquisition and Disposition Committee for the July 15, 2014 Town Council meeting.

Thank you.

To: Marcia Leclerc, Mayor, Town of East Hartford

Cc: Iris Laurenza, Tax Collector, Town of East Hartford

June 13, 2014

Dear Mayor,

I am part owner of three parcels of land in East Hartford which have been placed under a tax lien by the town and are subject for foreclosure auction on June 18, 2014.

I wish you to know that I have no interest in continuing to own my interest two of the parcels, those being located at 1855 & 1859 Main St, and that I offer to quit claim my interest in those properties to the Town of East Hartford.

In exchange I would ask to be absolved of all taxes owed on the properties known as 1855 & 1859 Main St.

I am also a part owner of a parcel of land at 38 Main St. Rear, which has taxes that have gone unpaid, that I am interested in owning. With regard to this parcel I would ask that the Town of East Hartford consider allowing me to bid on this parcel, as it is landlocked, and would likely not attract many buyers.

Should you have any questions, or wish to contact me to discuss, I would be pleased to explore any options which you may wish to pursue.

Sincerely,



Kevin R. Kearns

22 Buckwheat Hill Rd.

Watertown Ct. 06795

Telephone: 203 558-1668

Email: kearnskr@gmail.com

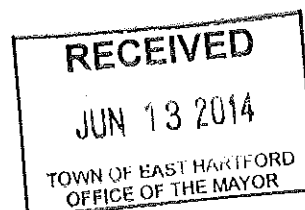

Vision ID: 8898

Account #8898

Bldg #: 1 of 1

Sec #: 1 of 1

Card 1 of 1

Print Date: 07/07/2014 14:52

| CURRENT OWNER | TOPO. | UTILITIES | STRT./ROAD | LOCATION | CURRENT ASSESSMENT | | | |
|-------------------------|--------|----------------|------------|----------|--------------------|------|-----------------|----------------|
| KEARNS KEVIN R | A Good | I All | I Paved | | Description | Code | Appraised Value | Assessed Value |
| 22 BUCK WHEAT HILL ROAD | | | | | VAC RS LN | 5-1 | 1,180 | 830 |
| SUPPLEMENTAL DATA | | | | | | | | |
| Other ID: 3150-1855 | | Loen Suffix | | | | | | |
| Homeowner Cr | | Zoning R-2 | | | | | | |
| Census 5108 | | Res Area 0 | | | | | | |
| VCS 3407 | | Non Res Area 0 | | | | | | |
| # Units 0 | | Lot Size .9 | | | | | | |
| Class Vac | | ASSOC PID# | | | | | | |
| GIS ID: | | | | | Total 1,180 830 | | | |

6043 EAST HARTFORD, CT

VISION

| RECORD OF OWNERSHIP | BK-VOL/PAGE | SALE DATE | q/u | w/i | SALE PRICE | V.C. | PREVIOUS ASSESSMENTS (HISTORY) | | | | | | | | | |
|-------------------------------|-------------|------------|-----|-----|------------|------|--------------------------------|------|----------------|------|------|----------------|--------|------|----------------|--|
| KEARNS KEVIN R | 3222/ 352 | 01/06/2011 | U | V | 0 | B11 | Yr. | Code | Assessed Value | Yr. | Code | Assessed Value | Yr. | Code | Assessed Value | |
| KEARNS KEVIN R | 2995/ 14 | 03/07/2008 | U | V | 0 | B08 | 2013 | 5-1 | 830 | 2012 | 5-1 | 830 | 2011 | 5-1 | 830 | |
| KEARNS KEVIN R | 2830/ 49 | 11/09/2006 | U | V | 0 | B11 | | | | | | | | | | |
| KEARNS WILLIAM R | 2344/ 22 | 12/23/2003 | U | V | 500 | B01 | | | | | | | | | | |
| KEARNS WILLIAM R & MARJORIE A | 2344/ 19 | 12/23/2003 | U | V | 500 | B00 | | | | | | | | | | |
| KEARNS WILLIAM R & THOMAS E | 1448/ 2 | 05/04/1993 | Q | V | 0 | NC | | | | | | | | | | |
| Total: | | | | | | | 830 | | Total: | | 830 | | Total: | | 830 | |

| EXEMPTIONS | | | | OTHER ASSESSMENTS | | | | This signature acknowledges a visit by a Data Collector or Assessor | | | | | | | |
|------------|------|-------------|--------|-------------------|-------------|--------|--------|---|--|--|--|--|--|--|--|
| Year | Type | Description | Amount | Code | Description | Number | Amount | Comm. Int. | | | | | | | |
| Total: | | | | | | | | | | | | | | | |

| ASSESSING NEIGHBORHOOD | | | | |
|------------------------|-----------|-------------------|---------|-------|
| NBHD/ SUB | NBHD Name | Street Index Name | Tracing | Batch |
| 0001/A | | | | |

| APPRAISED VALUE SUMMARY | | | | | | | | | | | |
|----------------------------------|--|--|--|--|--|--|--|--|--|-------|--|
| Appraised Bldg. Value (Card) | | | | | | | | | | 0 | |
| Appraised XF (B) Value (Bldg) | | | | | | | | | | 0 | |
| Appraised OB (L) Value (Bldg) | | | | | | | | | | 0 | |
| Appraised Land Value (Bldg) | | | | | | | | | | 1,180 | |
| Special Land Value | | | | | | | | | | 0 | |
| Total Appraised Parcel Value | | | | | | | | | | 1,180 | |
| Valuation Method: | | | | | | | | | | C | |
| Adjustment: | | | | | | | | | | 0 | |
| Net Total Appraised Parcel Value | | | | | | | | | | 1,180 | |

| BUILDING PERMIT RECORD | | | | | | | | VISIT/ CHANGE HISTORY | | | | | | |
|------------------------|------------|------|-------------|--------|------------|---------|------------|-----------------------|------------|------|----|----|-----|----------------|
| Permit ID | Issue Date | Type | Description | Amount | Insp. Date | % Comp. | Date Comp. | Comments | Date | Type | IS | ID | Cd. | Purpose/Result |
| | | | | | | | | | 11/01/1990 | | | AO | 60 | No Info |

| LAND LINE VALUATION SECTION | | | | | | | | | | | | | | | | | | | |
|-----------------------------|----------|-----------------|------|---|-------|-------|-------|------------|-----------|--------|-----------|---------|------|------------|-----------------|------------|-----------------|------------|-------|
| B # | Use Code | Use Description | Zone | D | Front | Depth | Units | Unit Price | I. Factor | S.A. | C. Factor | ST. Idx | Adj. | Notes- Adj | Special Pricing | S Adj Fact | Adj. Unit Price | Land Value | |
| 1 | 100 | Vacant | R2 | | | | 0.90 | AC | 60,802.00 | 1.0819 | 5 | 0.02 | 34 | 1.00 | SITE ADJ | | 1.00 | | 1,180 |

| CURRENT OWNER | | TOPO. | UTILITIES | STRT/ROAD | LOCATION | CURRENT ASSESSMENT | | | |
|------------------------|--|----------------|-----------|-----------|----------|--------------------|-------|-----------------|----------------|
| KEARNS KEVIN R | | A Good | 1 All | 1 Paved | | Description | Code | Appraised Value | Assessed Value |
| 22 BUCKWHEAT HILL RD | | | | | | VAC RS LN | 5-1 | 5,740 | 4,020 |
| WATERTOWN, CT 06795 | | | | | | | | | |
| Additional Owners: | | | | | | | | | |
| KEARNS THOMAS E EST OF | | | | | | | | | |
| BACHMAN WILLIAM A | | | | | | | | | |
| SUPPLEMENTAL DATA | | | | | | | | | |
| Other ID: 3150-1859 | | Locn Suffix | | | | | | | |
| Homeowner Cr | | Zoning R-2 | | | | | | | |
| Census 5108 | | Res Area 0 | | | | | | | |
| VCS 3407 | | Non Res Area 0 | | | | | | | |
| # Units 0 | | Lot Size 3.7 | | | | | | | |
| Class Vac | | ASSOC PID# | | | | | | | |
| GIS ID: | | | | | | | | | |
| | | | | | | | Total | 5,740 | 4,020 |

6043 EAST HARTFORD, CT

VISION

| RECORD OF OWNERSHIP | | BK-VOL/PAGE | SALE DATE | q/u | w/t | SALE PRICE | V.C. | PREVIOUS ASSESSMENTS (HISTORY) | | | | | | | | | |
|-------------------------------|--|-------------|------------|-----|-----|------------|--------|--------------------------------|------|----------------|------|-------|----------------|--------|------|----------------|-------|
| KEARNS KEVIN R | | 3222/ 352 | 01/06/2011 | U | V | 0 | B01 | Yr. | Code | Assessed Value | Yr. | Code | Assessed Value | Yr. | Code | Assessed Value | |
| KEARNS KEVIN R | | 2995/ 14 | 03/07/2008 | U | V | 0 | B08 | 2013 | 5-1 | | | | | | | | |
| KEARNS KEVIN R | | 2830/ 49 | 11/09/2006 | U | V | 0 | B11 | | | 4,020 | 2012 | 5-1 | | 4,020 | 2011 | 5-1 | |
| KEARNS WILLIAM R | | 2344/ 22 | 12/23/2003 | U | V | 500 | B01 | | | | | | | | | | 4,020 |
| KEARNS WILLIAM R & MARJORIE A | | 2344/ 19 | 12/23/2003 | U | V | 500 | B00 | | | | | | | | | | |
| KEARNS WILLIAM R & THOMAS E | | 1448/ 2 | 05/04/1993 | Q | V | 0 | NC | | | | | | | | | | |
| | | | | | | | Total: | 4,020 | | Total: | | 4,020 | | Total: | | 4,020 | |

| EXEMPTIONS | | | | OTHER ASSESSMENTS | | | |
|------------|------|-------------|--------|-------------------|-------------|--------|--------|
| Year | Type | Description | Amount | Code | Description | Number | Amount |
| | | | | | | | |
| Total: | | | | | | | |

This signature acknowledges a visit by a Data Collector or Assessor

| ASSESSING NEIGHBORHOOD | | | |
|------------------------|-----------|-------------------|---------|
| NBHD/ SUB | NBHD Name | Street Index Name | Tracing |
| 0001/A | | | |

| APPRAISED VALUE SUMMARY | |
|----------------------------------|-------|
| Appraised Bldg. Value (Card) | 0 |
| Appraised XF (B) Value (Bldg) | 0 |
| Appraised OB (L) Value (Bldg) | 0 |
| Appraised Land Value (Bldg) | 5,740 |
| Special Land Value | 0 |
| Total Appraised Parcel Value | 5,740 |
| Valuation Method: | C |
| Adjustment: | 0 |
| Net Total Appraised Parcel Value | 5,740 |

NOTES

| BUILDING PERMIT RECORD | | | | | | | |
|------------------------|------------|------|-------------|--------|------------|---------|------------|
| Permit ID | Issue Date | Type | Description | Amount | Insp. Date | % Comp. | Date Comp. |
| | | | | | | | |

| VISIT/ CHANGE HISTORY | | | | | |
|-----------------------|------|----|----|-----|----------------|
| Date | Type | IS | ID | Cd. | Purpose/Result |
| 11/01/1990 | | | AO | 60 | No Info |

| LAND LINE VALUATION SECTION | | | | | | | | | | | | | |
|-----------------------------|----------|-----------------|------|---|-------|-------|---------|------------|-----------|------|-----------|---------|-----------------|
| B # | Use Code | Use Description | Zone | D | Front | Depth | Units | Unit Price | I. Factor | S.A. | C. Factor | ST. Idx | Adj. |
| 1 | 100 | Vacant | R2 | | | | 3.70 AC | 60,802.00 | 0.5109 | 5 | 0.05 | 34 | 1.00 |
| | | | | | | | | | | | | | Notes- Adj |
| | | | | | | | | | | | | | SITE ADJ |
| | | | | | | | | | | | | | Special Pricing |
| | | | | | | | | | | | | | Spec Use |
| | | | | | | | | | | | | | Spec Calc |
| | | | | | | | | | | | | | S Adj Fact |
| | | | | | | | | | | | | | Adj. Unit Price |
| | | | | | | | | | | | | | Land Value |
| | | | | | | | | | | | | | 1.00 |
| | | | | | | | | | | | | | 5,740 |

Total Card Land Units: 3.70 AC Parcel Total Land Area: 3.7 AC

Total Land Value: 5,740

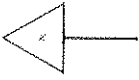

Assessor Map #16 / 27

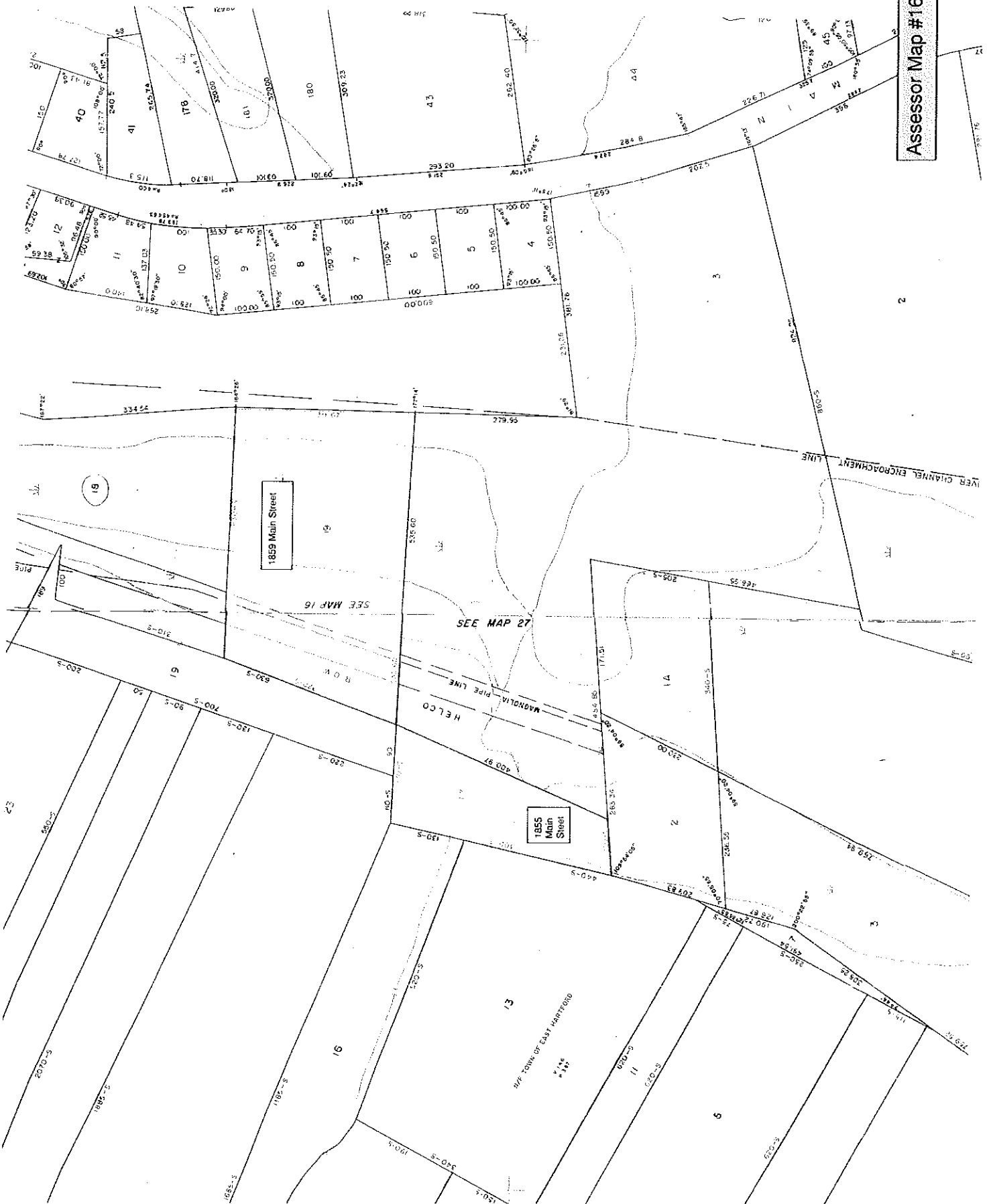

1859 Main Street

1855 Main Street

HELCO

MAGNOLIA PIPE LINE

RIVER CHANNEL ENCROACHMENT LINE

SEE MAP 16

SEE MAP 27

W/F TOWN OF EAST HARTFORD
#14
#146

23

27

Attenello, Angela

From: Gentile, Richard
Sent: Tuesday, July 01, 2014 3:30 PM
To: Kehoe, Richard
Cc: Walsh, Mike; Leclerc, Marcia
Subject: Public Act 14-124
Attachments: 2014PA-00124-R00HB-05140-PA.pdf

We may need to change the ordinance on tax relief to take into account this statutory change.

Richard P. Gentile
Assistant Corporation Counsel
Town of East Hartford
740 Main Street
East Hartford, CT 06108
rpgentile@easthartfordct.gov
860-291-7217



House Bill No. 5140

Public Act No. 14-124

***AN ACT CONCERNING PROPERTY TAX RELIEF ON CERTAIN
REAL PROPERTY HELD IN TRUST.***

Be it enacted by the Senate and House of Representatives in General Assembly convened:

Section 1. Subsection (a) of section 12-129n of the general statutes is repealed and the following is substituted in lieu thereof (*Effective October 1, 2014, and applicable to assessment years commencing on and after said date*):

(a) Any municipality may, by vote of its legislative body on recommendation of its board of finance or equivalent body, provide property tax relief to residents of such municipality, with respect to real property owned and occupied by such residents as their principal residence, or held in trust for and occupied by such residents as their principal residence, who are (1) sixty-five years of age and over, or whose spouses, living with them, are sixty-five years of age or over or sixty years of age or over and the surviving spouse of a taxpayer qualified in such municipality under this section at the time of his or her death or with respect to real property on which such residents or their spouses are liable for taxes under section 12-48, or (2) under age sixty-five and eligible in accordance with applicable federal regulations to receive permanent total disability benefits under Social Security, or have not been engaged in employment covered by Social

House Bill No. 5140

Security and accordingly have not qualified for benefits thereunder, but have become qualified for permanent total disability benefits under any federal, state or local government retirement or disability plan, including the Railroad Retirement Act and any government-related teacher's retirement plan, in which requirements with respect to qualifications for such permanent total disability benefits are comparable to such requirements under Social Security, provided such residents or their spouses under subdivisions (1) or (2) above have been taxpayers of such municipality for one year immediately preceding their receipt of tax benefits under this section, and meet the requirements which may be established by such municipality with respect to maximum income allowable during the calendar year preceding the year in which application is made for the tax relief provided in this section. No such property tax relief, together with any relief received by any such resident under the provisions of sections 12-129b to 12-129d, inclusive, and 12-170aa shall exceed, in the aggregate the total amount of the tax which would, except for said sections 12-129b to 12-129d, inclusive, 12-170aa and this section, be laid against the taxpayer.

Approved June 6, 2014

MARCIA A. LECLERC
MAYOR

TOWN OF EAST HARTFORD
Police Department

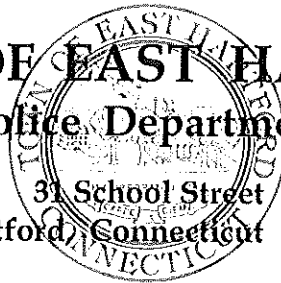

East Hartford, Connecticut 06108-2638

TELEPHONE
(860) 528-4401

FAX (860) 289-1249

SCOTT M. SANSOM
CHIEF OF POLICE

www.easthartfordct.gov

July 7, 2014

Richard F. Kehoe, Chairman
East Hartford Town Council
740 Main Street
East Hartford, CT 06108

**Re: Outdoor Amusement Permit Application -
"Gengras Harley-Davidson Fall Open House"**

Dear Chairman Kehoe:

Attached please find a copy of the amusement permit application submitted by **Gengras Motor Cars, Inc. by Hannah Gavin, its Events Coordinator**. The applicant seeks to conduct a Fall Open House. Two (2) motorcycle stunt shows each day by Luke Emmons. The events will also include specials on merchandise and feature music (DJ), food, sales and vendors. The weekend event will be held at **221 Governor Street**, on the following days and times in 2014:

| | | |
|-------------------------------|-------------------|-------------------------|
| Saturday, September 20 | 9AM – 5PM | Music 9 AM – 5PM |
| Sunday, September 21 | 10AM – 3PM | Music 10AM – 3PM |

Pursuant to Town Ordinance (TO) 5-3, a review of the application was completed by the Directors of the Fire, Health, Parks & Recreation, Public Works Departments and the Offices of the Corporation Counsel and Finance.

The **Office of Corporation Counsel** approves the application as submitted.

The **Parks & Recreation, Fire, Public Works and Health Departments** approve the application as submitted and state **there are no anticipated costs to their Departments for this event.**

The **Risk Management Department** states that a Certificate of Insurance for One (1) Million Dollars general liability will be required. The Town of East Hartford must be named and endorsed on the general liability policy as additional insured for the two (2) day open house.

The **Police Department** conducted a review of the application and the following comments/recommendations are made:

- The Police Department can provide adequate police protection for the events. The site is suitable for the outdoor amusement, the expected crowds are of small to moderate size, and the area has sufficient parking available.
- **There are no anticipated costs to the Department for this event.**

Respectfully submitted for your information.

Sincerely,

A handwritten signature in black ink, appearing to read "Scott M. Sansom". The signature is fluid and cursive, with the first name "Scott" being more prominent and the last name "Sansom" following in a similar style.

Scott M. Sansom
Chief of Police

Cc: Applicant

TOWN OF EAST HARTFORD POLICE DEPARTMENT



Marcia A. Leclerc
Mayor

OUTDOOR AMUSEMENT PERMITS
31 SCHOOL STREET
EAST HARTFORD, CT 06108-2638
(860) 528-4401

OUTDOOR AMUSEMENT PERMIT APPLICATION



Scott M. Sansom
Chief of Police

THIS APPLICATION IS DUE NOT LESS THAN 30 DAYS PRIOR TO THE EVENT APPLIED FOR

1. Name of Event:
Gengras Harley-Davidson Fall Open House
2. Date(s) of Event:
Sept. 20th & 21st
3. Applicant's name, home & work phone numbers, home address, and e-mail address (NOTE: If applicant is a partnership, corporation, limited liability company, club or association give the full legal name of the Applicant) :
Gengras Motor Cars, Inc.
300 CT Blvd, East Hartford, CT 06108
By: Hannah Gavin, Events Coordinator Home:860-967-7912
Work:860-727-6623 82 Horse Pond Rd Salem CT 06420
hgavin@gengras.com
4. If Applicant is a partnership, corporation, limited liability company , club, or association, list the names of all partners, members, directors and officers AND provide their business address.
Skip Gengras, Chip Gengras, Jonathon Gengras, Gengras Motorcycles Inc.,
300 Connecticut Blvd, East Hartford, CT 06108
5. List the location of the proposed amusement: (Name of facility and address)
Gengras Harley-Davidson/Gengras Motorcycles, 221 Governor St. E.Hartford
6. List the dates and hours of operation for each day (if location changes on a particular day, please list):
Sat. Sept. 20th 9a-5p Sun. Sept. 21st 10a-3p
7. Provide a detailed description of the proposed amusement:
2 motorcycle stunt shows each day by Luke Emmons and DJ outside, specials on merchandise and accessories inside

8. Will music or other entertainment be provided wholly or partially outdoors?

Yes No

a. If 'YES,' during what days and hours will music or entertainment be provided (note: this is different from hours of operation)? **Sat. 9-5, Sun 10-3 during our normal hours**

9. What is the expected age group(s) of participants?

All activities are designed for all ages

10. What is the expected attendance at the proposed amusement:

(If more than one performance, indicate time / day / date and anticipated attendance for each.)

Sept. 20th 250 people, Sept. 21st 200 people

11. Provide a detailed description of the proposed amusement's anticipated impact on the surrounding community. Please comment on each topic below:

a. Crowd size impact:

Crowd impact will be minimal. Gengras H-D provides ample parking

b. Traffic control and flow plan at site & impact on surrounding / supporting streets:

No impact expected, as we are easily accessible from multiple routes

c. Parking plan on site & impact on surrounding / supporting streets:

Little to no impact as we have ample car and motorcycle parking in our lot

d. Noise impact on neighborhood:

Minimal as we are located in a commercial building zone & during normal hours

e. Trash & litter control plan for the amusement site and surrounding community during and immediately after the proposed amusement:

Gengras H-D staff will be responsible for trash disposal

f. List expected general disruption to neighborhood's normal life and activities:

None

g. Other expected influence on surrounding neighborhood:

None

12. Provide a detailed plan for the following:

a. Accessibility of amusement site to emergency, police, fire & medical personnel and vehicles:

Entrances will be kept clear, as well as fire lanes in case of an emergency

b. Provisions for notification of proper authorities in the case of an emergency:

Multiple on site phones are available in case of an emergency

c. Any provision for on-site emergency medical services:

None

d. Crowd control plan:

Activities in different areas and staff to guide attendees will keep crowd control

e. If on town property, the plan for the return of the amusement site to pre-amusement condition:

N/A

f. Provision of sanitary facilities:

In addition to on-site restrooms, we will provide additional port-a-lettes

13. Will food be provided, served, or sold on site:

Food available Yes No AND contact has been made with the East Hartford Health

Department Yes No.

14. Does the proposed amusement involve the sale and/or provision of alcoholic beverages to amusement attendees,

Yes No Alcoholic beverages will be served / provided.

If 'YES', describe, in detail, any and all arrangements and what procedures shall be employed:

a. For such sale or provision,

b. To ensure that alcohol is not sold or provided to minors or intoxicated persons.

Check if copy of the liquor permit, as required by State law, is included with application.

15. Include any other information which the applicant deems relevant (ie: time waivers and fee waiver requests should go here):

CGS Sec. 53a-157. False Statement: Class A Misdemeanor.

A person is guilty of False Statement when he intentionally makes a false written statement under oath or pursuant to a form bearing notice, authorized by law, to the effect that false statements made therein are punishable, which he does not believe to be true and which statement is intended to mislead a public servant in the performance of his official duties.

a. False Statement is a Class A Misdemeanor.

b. The penalty for a Class A Misdemeanor is imprisonment for a term not to exceed one (1) year, or a fine not to exceed \$1,000, or both a fine and imprisonment.

I declare, under the penalties of False Statement, that the information provided in this application is true and correct to the best of my knowledge:

Hannah Gavin
(Legal Name of Applicant)

[Signature]
(Applicant Signature)

Hannah Gavin
(Printed Name)

6/20/14
(Date Signed)

Event Coordinator, Gengras Motorcycles
(Capacity in which signing)

(Send application electronically to cfrank@easthartfordet.gov)

FOR OFFICE USE

Insurance Certificate Included:

YES

NO

Liquor Permit Included:

YES

NO

Certificate of Alcohol Liability Included:

YES

NO

Time Waiver Request Included:

YES

NO

Fee Waiver Request Included:

YES

NO

Received By: Carol O'Connell
Employee Number: 9019
Date & Time Signed: 6/23/14 7:35 AM PM
Time remaining before event: 30⁺ days.

If roads or sidewalks will be closed to public use as a result of this event the applicant must comply with signage requirements per Section 5-4 and present a signed affidavit attesting to this at the Town Council meeting.



Scott M. Sansom
Chief of Police

TOWN OF EAST HARTFORD
POLICE DEPARTMENT
Outdoor Amusement Permits
31 School Street
East Hartford, CT 06108
(860) 528-4401



Marcia A. Leclerc
Mayor

Administrative Review of Amusement Permit

Event Date: September 20 & 21, 2014

Event: Gengras H-D Fall Open House

Applicant: Gengras Motor Cars, Inc. by Hannah Gavin, its Events Coordinator

Pursuant to Town Ordinance (TO) 5-3, a review of the application was completed and the following recommendation is made:

- 1. the application be approved as submitted.
- 2. the application be revised, approved subject to the condition(s) set forth in the attached comments.
- 3. the application be disapproved for the reason(s) set forth in the attached comments.

- Fire Department
- Health Department
- Parks & Recreation Department
- Public Works Department
- Corporation Counsel

Anticipated Cost(s) if known \$ 0

Signature [Handwritten Signature] Date 6/25/14

Comments:

No Services Required From FD

Health Dept



Scott M. Sansom
Chief of Police

**TOWN OF EAST HARTFORD
POLICE DEPARTMENT**
Outdoor Amusement Permits
31 School Street
East Hartford, CT 06108
(860) 528-4401



Marcia A. Leclerc
Mayor

Administrative Review of Amusement Permit

Event Date: **September 20 & 21, 2014**

Event: **Gengras H-D Fall Open House**

Applicant: **Gengras Motor Cars, Inc. by Hannah Gavin, its Events Coordinator**

Pursuant to Town Ordinance (TO) 5-3, a review of the application was completed and the following recommendation is made:

- 1. the application be approved as submitted.
- 2. the application be revised, approved subject to the condition(s) set forth in the attached comments.
- 3. the application be disapproved for the reason(s) set forth in the attached comments.

- Fire Department
- Health Department
- Parks & Recreation Department
- Public Works Department
- Corporation Counsel

Anticipated Cost(s) if known \$ 0

Michael S. O'Connell
Signature

6/23/14
Date

Comments:



Scott M. Sansom
Chief of Police

TOWN OF EAST HARTFORD
POLICE DEPARTMENT
Outdoor Amusement Permits
31 School Street
East Hartford, CT 06108
(860) 528-4401



Marcia A. Leclerc
Mayor

Administrative Review of Amusement Permit

Event Date: **September 20 & 21, 2014**

Event: **Gengras H-D Fall Open House**

Applicant: **Gengras Motor Cars, Inc. by Hannah Gavin, its Events Coordinator**

Pursuant to Town Ordinance (TO) 5-3, a review of the application was completed and the following recommendation is made:

- 1. the application be approved as submitted.
 - 2. the application be revised, approved subject to the condition(s) set forth in the attached comments.
 - 3. the application be disapproved for the reason(s) set forth in the attached comments.
-
- Fire Department
 - Health Department
 - Parks & Recreation Department
 - Public Works Department
 - Corporation Counsel
-
- Anticipated Cost(s) if known \$0.00

Ted Frauel

Signature

7/7/14

Date

Comments:

Frank, Carol

From: Milkove, Tess
Sent: Monday, July 07, 2014 9:38 AM
To: Frank, Carol
Cc: Bockus, Tim
Subject: RE: Gengras HD Fall Open House

Carol,

I have reviewed this application and Pursuant to Town Ordinance 5.3 I recommend that the application be approved.

There are no anticipated costs to the department.

Thanks,

Tess Milkove, PE
Assistant Director of Public Works
Town of East Hartford
740 Main Street
East Hartford, CT 06108
Phone 860 291 7365
Fax (860) 291-7370

From: Frank, Carol
Sent: Monday, July 07, 2014 8:01 AM
To: Fravel, Theodore; Milkove, Tess
Cc: Collins, Courtney; Francis, Nancy; Orzolek, Mary
Subject: Gengras HD Fall Open House

Good day all –

Just a reminder that your review for the above captioned event is due today, Monday, July 7th. Thank you.

Carol A. Frank
East Hartford Police Department
Support Services Bureau
31 School Street
East Hartford, CT 06108

Ph: 860-291-7631
Fax: 860-610-6290

Frank, Carol

From: Gentile, Richard
Sent: Monday, June 23, 2014 9:02 AM
To: Frank, Carol
Subject: RE: Gengras Harley-Davidson Fall Open House

Application should be signed on behalf of the applicant, Gengras Motor Cars, Inc., not Gengras Motorcycles.

From: Frank, Carol
Sent: Monday, June 23, 2014 7:49 AM
To: Bockus, Tim; Cordier, James; Fravel, Theodore; Oates, John
Cc: Bennett, Cindy; Cohen, Bruce; DeMaine, Michael; Gentile, Richard; Grew, Greg; Horan, Denise; Leclerc, Marcia; McConville, Timothy; Milkove, Tess; O'Connell, Michael; Perez, William; Sansom, Scott; Stokes, Gloria; Uhrig, Jim
Subject: Gengras Harley-Davidson Fall Open House

Good morning all.

Attached please find the Outdoor Amusement Permit Application and your Director's Review and Notice in connection with the above captioned event.

Please note the review is attached to the notice and your review can be sent via an e-mail response, through Outlook or print, sign, and interoffice review, TO MY ATTENTION AT THE POLICE DEPARTMENT **by Monday, July 7, 2014**. Thank you.

If you should have any questions, please feel free to contact me.

Carol A. Frank
East Hartford Police Department
Support Services Bureau
31 School Street
East Hartford, CT 06108

Ph: 860-291-7631
Fax: 860-610-6290

Task Mngmt

Frank, Carol

From: Bennett, Cindy
Sent: Monday, June 23, 2014 9:54 AM
To: Frank, Carol
Subject: RE: Gengras Harley-Davidson Fall Open House

I will need a certificate of ins for this event

From: Frank, Carol
Sent: Monday, June 23, 2014 7:49 AM
To: Bockus, Tim; Cordier, James; Fravel, Theodore; Oates, John
Cc: Bennett, Cindy; Cohen, Bruce; DeMaine, Michael; Gentile, Richard; Grew, Greg; Horan, Denise; Leclerc, Marcia; McConville, Timothy; Milkove, Tess; O'Connell, Michael; Perez, William; Sansom, Scott; Stokes, Gloria; Uhrig, Jim
Subject: Gengras Harley-Davidson Fall Open House

Good morning all.

Attached please find the Outdoor Amusement Permit Application and your Director's Review and Notice in connection with the above captioned event.

Please note the review is attached to the notice and your review can be sent via an e-mail response, through Outlook or print, sign, and interoffice review, TO MY ATTENTION AT THE POLICE DEPARTMENT **by Monday, July 7, 2014**. Thank you.

If you should have any questions, please feel free to contact me.

Carol A. Frank
East Hartford Police Department
Support Services Bureau
31 School Street
East Hartford, CT 06108

Ph: 860-291-7631
Fax: 860-610-6290

Frank, Carol

From: DeMaine, Michael
Sent: Monday, July 07, 2014 11:46 AM
To: Frank, Carol
Subject: Re: Gengras HD Fall Open House

Extra attention only

Sent from my iPhone

On Jul 7, 2014, at 11:38 AM, "Frank, Carol" <CFrank@easthartfordct.gov> wrote:

Thanks Mike.

Can you do me a quick favor – when you send your reviews, please let me know if you are hiring or if the event only require extra or special attention. I need it in the file. Appreciate the help.

Carol

From: DeMaine, Michael
Sent: Monday, July 07, 2014 11:28 AM
To: Frank, Carol
Subject: RE: Gengras HD Fall Open House

I have no issue with this event.

Sergeant Michael DeMaine
Public Information Officer/Special Events
East Hartford Police Department
31 School Street
East Hartford, CT 06108
Office (860)291-7583
Fax (860)289-1249
mdemaine@easthartfordct.gov

From: Frank, Carol
Sent: Monday, July 07, 2014 9:29 AM
To: DeMaine, Michael
Subject: Gengras HD Fall Open House

Mike,

Just a reminder that your review for the above captioned event is due today. I have attached the information for you.

Carol A. Frank
East Hartford Police Department

Frank, Carol

From: Grew, Greg
Sent: Monday, June 23, 2014 8:10 AM
To: Frank, Carol
Subject: RE: Gengras Harley-Davidson Fall Open House

Carol,
Per ordinance 5-3 my review and approval is not required. Permits may be needed for temporary installations and utilities.

Greg
Milton Gregory Grew, AIA
Director of Dept. of Inspections & Permits
Town of East Hartford, CT
T 860-291-7345 M 860-874-8034

Sent from Verizon Wireless 4G LTE Tablet

----- Original message -----

From: "Frank, Carol" <CFrank@easthartfordct.gov>
Date: 06/23/2014 7:49 AM (GMT-05:00)
To: "Bockus, Tim" <Tbockus@easthartfordct.gov>,"Cordier, James" <jcordier@easthartfordct.gov>,"Fravel, Theodore" <tfravel@easthartfordct.gov>,"Oates, John" <Joates@easthartfordct.gov>
Cc: "Bennett, Cindy" <CBennett@easthartfordct.gov>,"Cohen, Bruce" <BCohen@easthartfordct.gov>,"DeMaine, Michael" <Mdemaine@easthartfordct.gov>,"Gentile, Richard" <RPGentile@easthartfordct.gov>,"Grew, Greg" <inggrew@easthartfordct.gov>,"Horan, Denise" <Dhoran@easthartfordct.gov>,"Leclerc, Marcia" <MLEclerc@easthartfordct.gov>,"McConville, Timothy" <Tmconville@easthartfordct.gov>,"Milkove, Tess" <tmilkove@easthartfordct.gov>,"O'Connell, Michael" <Moconnell@easthartfordct.gov>,"Perez, William" <Wperez@easthartfordct.gov>,"Sansom, Scott" <SSansom@easthartfordct.gov>,"Stokes, Gloria" <Gstokes@easthartfordct.gov>,"Uhrig, Jim" <Juhrig@easthartfordct.gov>
Subject: Gengras Harley-Davidson Fall Open House

Good morning all.

Attached please find the Outdoor Amusement Permit Application and your Director's Review and Notice in connection with the above captioned event.

Robert J. Peck

OFFICE OF THE
TOWN COUNCIL

TOWN OF EAST HARTFORD

740 Main Street

East Hartford, Connecticut 06108

2014 JUL 10 AM 11:31
(860) 291-7208

TOWN CLERK (860) 291-7389
EAST HARTFORD

DATE: July 10, 2014

TO: Town Council Members

FROM: Rich Kehoe, Chair

RE: Tuesday, July 15, 2014 6:30 p.m. Town Council Majority Office

In accordance with Section 3.3 (a) of the Town Charter, a Special Meeting of the Town Council will be held as follows:

Tuesday, July 15, 2014

6:30 p.m.

Town Council Majority Office

The purpose of the meeting is to meet in executive session to discuss the following pending Superior Court actions:

- Brookside Commons vs Town of East Hartford, Docket No. HHB-CV-12-6016052S
- TE Realty Enterprises vs Town of East Hartford, Docket No. HHB-CV-13-6020777S

cc: Mayor Leclerc
Scott Chadwick, Corporation Counsel
Brian Smith, Assessor